

SAMSUNG

DVM

Technical Data Book

**DVM S2 + for Europe
(R32, 50Hz, Heat Pump)**

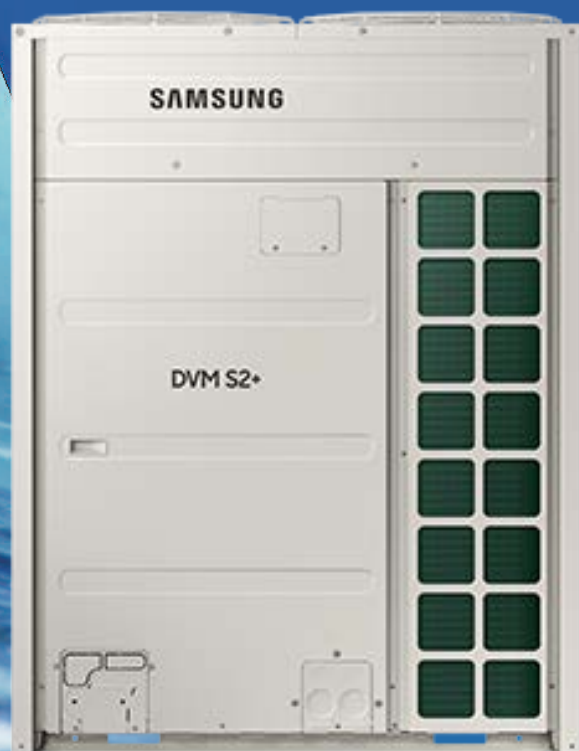

History

Version	Modification	Date
Ver. 1.0	Released DVM S2 (R32) TDB for Europe	25.04.23
Ver. 1.1	Updated specification pages	25.11.21
Ver. 2.0	Released DVM S2+ TDB for Europe	25.12.29

Nomenclature

Outdoor Unit

Model Name

AM	080	H	C	V	A	N	G	/	EU
(1)	(2)	(3)	(4)	(5)	(6)	(7)	(8)	(9)	Buyer

(1) Classification

AM	DVM
-----------	-----

(2) Capacity

x 1/10 HP (3 digits)

(3) Year

H	2026
----------	------

(4) Product Type

C	Outdoor Unit
----------	--------------

(5) Feature 1

V	DVM Inverter
----------	--------------

(6) Feature 2

A	STANDARD+GENERAL Temp.+MODULE
----------	-------------------------------

(7) Rating Voltage

N	380~415V, 50/60Hz, 3Φ
----------	-----------------------

(8) Mode

G	Heat Pump (R32/R454B)
----------	-----------------------

(9) Version

/	Basic
----------	-------







Contents

1. Line-Up	5
2. Specification	6
3. Summary Table	24
4. Dimensional Drawing	25
5. Center of Gravity	28
6. Electrical Wiring Diagram	31
7. Sound Data	34
8. Operation Range	38
9. Piping Diagram	40
10. Installation	44

1. Line-Up

Combination Table

Standard

System Model									
Capacity	Model code	Number of individual outdoor	8	10	12	14	16	18	20
HP									
8	AM080HCVANG/EU	1	1						
10	AM100HCVANG/EU	1		1					
12	AM120HCVANG/EU	1			1				
14	AM140HCVANG/EU	1				1			
16	AM160HCVANG/EU	1					1		
18	AM180HCVANG/EU	1						1	
20	AM200HCVANG/EU	1							1
22	AM220HCVANG/EU	2		1	1				
24	AM240HCVANG/EU	2		1		1			
26	AM260HCVANG/EU	2	1					1	
28	AM280HCVANG/EU	2		1				1	
30	AM300HCVANG/EU	2			1			1	
32	AM320HCVANG/EU	2				1		1	
34	AM340HCVANG/EU	2					1	1	
36	AM360HCVANG/EU	2						2	
38	AM380HCVANG/EU	2						1	1
40	AM400HCVANG/EU	2							2
42	AM420HCVANG/EU	3			2			1	
44	AM440HCVANG/EU	3	1					2	
46	AM460HCVANG/EU	3		1				2	
48	AM480HCVANG/EU	3			1			2	
50	AM500HCVANG/EU	3				1		2	
52	AM520HCVANG/EU	3					1	2	
54	AM540HCVANG/EU	3						3	
56	AM560HCVANG/EU	3						2	1
58	AM580HCVANG/EU	3						1	2
60	AM600HCVANG/EU	3							3

NOTE

- Make sure to use an indoor unit that is compatible with DVM S2+.
- Indoor units can be connected within the range indicated in following table.
- If the total capacity of the connected indoor units exceeds the indicated maximum capacity, cooling and heating capacity of the indoor unit may decrease.
- Total capacity of the connected indoor units can be allowed from 50% to 130% of the total outdoor unit capacity.
 $0.5 \times \Sigma(\text{Outdoor unit capacity}) \leq \text{Total capacity of the connected indoor units} \leq 1.3 \times \Sigma(\text{Outdoor unit capacity})$
- ※ You can connect maximum 64 indoor units to the outdoor unit.
 Maximum quantity of connectable indoor unit is set to 64 since outdoor unit only support up to 64 communication address.
 Indoor unit address can be assigned from 0~63. If the indoor unit address was assigned from 64~79, E201 error will occur.
- ※ Maximum 32 Wall-mount type indoor units with EEV (AM***DNVDKG/EU, AM***DNQDKG/EU) can be connected.

2. Specification

Standard

Model Code	Outdoor Unit			-	AM080HCVANG/EU	AM100HCVANG/EU	AM120HCVANG/EU
	Outdoor Unit1			-	-	-	-
	Outdoor Unit2			-	-	-	-
	Outdoor Unit3			-	-	-	-
	Outdoor Unit4			-	-	-	-
Power Supply				Φ # V Hz	3 4 380-415 50	3 4 380-415 50	3 4 380-415 50
Mode				-	Heat Pump	Heat Pump	Heat Pump
Performance	HP				8	10	12
	kW				22.4	28.0	33.6
	Capacity	Cooling	Rated	kW	22.4	28.0	33.6
			Heating	Rated	kW	22.4	28.0
				Max	kW	25.2	31.5
Connectable indoor units	Maximum number of connectable indoor units			EA	14	18	21
	Total capacity of the connected Indoor Units		Min.	kW	11.2	14.0	16.8
			Max.	kW	29.1	36.4	43.7
Power	Current Input	Cooling	Rated/Ducted	A	10.53	13.80	15.66
			Rated/Non-Ducted	A	7.71	9.85	12.10
		Heating	Rated/Ducted	A	10.73	13.50	17.21
			Rated/Non-Ducted	A	8.26	10.65	13.10
	Current	Minimum Ssc		MVA	3.0	3.7	4.0
		MCA		A	18.0	23.0	25.0
		MFA		A	25	32	32
Efficiency	Cooling	SEER	Ducted	W/W	8.08	7.60	7.40
			Non-Ducted	W/W	7.90	7.70	7.60
		ηs,c	Ducted	%	320.20	301.00	293.00
			Non-Ducted	%	313.00	305.00	301.00
	Heating	SCOP	Ducted	W/W	4.35	4.30	4.40
			Non-Ducted	W/W	4.61	4.42	4.37
		ηs,h	Ducted	%	171.00	169.00	173.00
			Non-Ducted	%	181.30	173.70	171.80
Pdesignh			kW	13.70	15.20	18.40	
Casing	Material	Body	-	GI Steel Plate	GI Steel Plate	GI Steel Plate	
		Base	-	GI Steel Plate	GI Steel Plate	GI Steel Plate	
Heat Exchanger	Type			-	Fin & Tube	Fin & Tube	Fin & Tube
	Material	Fin	-	AL	AL	AL	
		Tube	-	Cu	Cu	Cu	
	Fin Treatment			-	Anti-corrosion	Anti-corrosion	Anti-corrosion
Compressor	Model Name			-	DS2BD7046FVA	DS4BC7066FVA	DS4BC7066FVA
	Quantity			EA	1	1	1
	Type			-	SCROLL_INVERTER	SCROLL_INVERTER	SCROLL_INVERTER
	Output			kW	4.95	7.17	7.17
	Oil	Type		-	POE	POE	POE
		Initial Charge		cc	900	1,100	1,100
Fan	Type			-	Propeller	Propeller	Propeller
	Discharge direction			-	Top discharge	Top discharge	Top discharge
	Quantity			EA	1	1	1
	Air Flow Rate			CMM	151	167	196
	External Static Pressure			Pa	110	110	110
mmAq				11	11	11	
Fan Motor	Type			-	BLDC	BLDC	BLDC
	Output			W	630	630	630
				kW	0.63	0.63	0.63

2. Specification

Standard

Model Code	Outdoor Unit		-	AM080HCVANG/EU	AM100HCVANG/EU	AM120HCVANG/EU	
	Outdoor Unit1		-	-	-	-	
	Outdoor Unit2		-	-	-	-	
	Outdoor Unit3		-	-	-	-	
	Outdoor Unit4		-	-	-	-	
Piping Connections	Liquid Pipe	Type	-	Welding	Welding	Welding	
		Diameter	mm	9.52	9.52	12.7	
	Gas Pipe	Type	-	Welding	Welding	Welding	
		Diameter	mm	19.05	22.22	22.22	
	Heat Insulation		-	Both liquid and gas pipes	Both liquid and gas pipes	Both liquid and gas pipes	
	Total piping length (System)		Max.	m	1,000	1,000	1,000
	Piping length (1st Branch-IDU)		Max.	m	90	90	90
	Piping length (ODU-IDU)		Max.	m	200	200	200
	Piping length (ODU-IDU)	Equivalent	Max.	m	220	220	220
	Level difference (IDU-IDU)		Max.	m	50	50	50
	Level difference (ODU in highest position)		Max.	m	110	110	110
	Level difference (IDU in highest position)		Max.	m	110	110	110
Wiring Connection	Transmiss on Cable	Min.	mm ²	0.75	0.75	0.75	
		Remark	-	F1, F2	F1, F2	F1, F2	
Refrigerant	Type		-	R32	R32	R32	
	Factory Charge		kg	7.0	7.0	9.3	
			tCO ₂ e	4.73	4.73	6.28	
Sound Level	Sound Pressure Level	Cooling	dB(A)	53	56	61	
		Heating	dB(A)	58	60	63	
	Sound Power Level	Cooling	dB(A)	75	78	81	
External Dimension	Net Weight		kg	183.0	193.0	214.0	
	Shipping Weight		kg	197.0	207.0	228.0	
	Net Dimensions	W x H x D	mm	930 x 1,695 x 765	930 x 1,695 x 765	930 x 1,695 x 765	
	Shipping Dimensions	W x H x D	mm	998 x 1,887 x 829	998 x 1,887 x 829	998 x 1,887 x 829	
Operating Temp. Range	Cooling	Min. ~ Max.	°C	-5 ~ 52	-5 ~ 52	-5 ~ 52	
	Heating	Min. ~ Max.	°C	-30 ~ 24	-30 ~ 24	-30 ~ 24	

NOTE

- Specification may be subject to change without prior notice.
 - Specification comply with EN14825 and Eurovent test condition.
- 1) Performances are based on the following test conditions.
 - Cooling : Indoor temperature 27°CDB, 19°CWB, Outdoor temperature 35°CDB, 24°CWB
 - Heating : Indoor temperature 20°CDB, 15°CWB, Outdoor temperature 7°CDB, 6°CWB
 - Equivalent refrigerant pipe length 5m, Level differences 0m
 - Refer to EUROVENT website(www.eurovent-certification.com) for other indoor unit combination and more detail test conditions.
 - 2) Performance of Multiple Module Outdoor unit is weighted average of Single Module outdoor units.
 - 3) Allowed combination ratio of the total rated indoor unit capacity over the rated outdoor unit capacity is 50~130%.
 - 4) Sound pressure level is obtained in an anechoic room.
 - Sound pressure level is a relative value, depending on the distance and acoustic environment.
 - Sound pressure level may differ depending on operation condition.
 - dBA = A-weighted sound pressure level
 - Reference acoustic pressure 0 dB = 20uPa
 - 5) Sound power level is an absolute value that a sound source generates.
 - dBA = A-weighted sound power level
 - Reference power : 1pW
 - Measured according to ISO 3741
 - 6) Sound values of multi combination are theoretical values based on sound results of individual installed units.
 - 7) These products contain R32 (GWP=675) which is fluorinated greenhouse gas.
 - 8) If outdoor unit is located in a higher position than indoor unit, level difference is 110m or under.
 - (If the level difference is higher than 50m, make a decision by PDM kit installation Guide software whether the PDM kit should be installed or not.)
 - PDM kit: Pressure Drop Modulation kit
 - When the outdoor unit is below the indoor unit & the level differences are 40m or more, contact your local dealer for more information.
 - 9) In case you want to know more information regarding capacity and correction, please refer to capacity table TDB on pvi.samsung.com site.
 - 10) Recommended combination

Ducted

Capacity	Indoor Units	Capacity	Indoor Units
8HP	AM056DNMFKG/EU × 4	16HP	AM071DNMFKG/EU × 6
10HP	AM071DNMFKG/EU × 4	18HP	AM071DNMFKG/EU×4 + AM056DNMFKG/EU×4
12HP	AM056DNMFKG/EU × 6	20HP	AM071DNMFKG/EU × 8
14HP	AM071DNMFKG/EU×5 + AM056DNMFKG/EU×1		

Non-Ducted

Capacity	Indoor Units	Capacity	Indoor Units
8HP	AM056DN4FKG/EU × 4	16HP	AM071DN4FKG/EU × 6
10HP	AM071DN4FKG/EU × 4	18HP	AM071DN4FKG/EU×4 + AM056DN4FKG/EU×4
12HP	AM056DN4FKG/EU × 6	20HP	AM071DN4FKG/EU × 8
14HP	AM071DN4FKG/EU×5 + AM056DN4FKG/EU×1		

2. Specification

Standard

Model Code	Outdoor Unit			-	AM140HCVANG/EU	AM160HCVANG/EU	AM180HCVANG/EU
	Outdoor Unit1			-	-	-	-
	Outdoor Unit2			-	-	-	-
	Outdoor Unit3			-	-	-	-
	Outdoor Unit4			-	-	-	-
Power Supply				Φ # V Hz	3 4 380-415 50	3 4 380-415 50	3 4 380-415 50
Mode				-	Heat Pump	Heat Pump	Heat Pump
Performance	HP				14	16	18
	kW				40.0	45.0	50.4
	Capacity	Cooling	Rated	kW	40.0	45.0	50.4
			Heating	Rated	kW	40.0	45.0
				Max	kW	45.0	50.4
Connectable indoor units	Maximum number of connectable indoor units			EA	26	29	32
	Total capacity of the connected Indoor Units		Min.	kW	20.0	22.5	25.2
			Max.	kW	52.0	58.5	65.5
Power	Current Input	Cooling	Rated/Ducted	A	19.10	23.59	25.15
			Rated/Non-Ducted	A	14.75	16.91	19.51
		Heating	Rated/Ducted	A	20.76	24.68	24.68
			Rated/Non-Ducted	A	14.27	16.39	17.70
	Current	Minimum Ssc		MVA	4.6	5.2	6.3
		MCA		A	29.0	32.0	39.2
		MFA		A	32	40	50
Efficiency	Cooling	SEER	Ducted	W/W	7.90	8.03	7.73
			Non-Ducted	W/W	7.70	8.45	7.90
		η _{s,c}	Ducted	%	313.00	318.20	306.20
			Non-Ducted	%	305.00	335.00	313.00
	Heating	SCOP	Ducted	W/W	4.60	4.71	4.43
			Non-Ducted	W/W	4.40	4.90	4.70
		η _{s,h}	Ducted	%	181.00	185.40	174.20
			Non-Ducted	%	173.00	193.00	185.00
Pdesignh			kW	20.30	23.20	26.50	
Casing	Material	Body		-	GI Steel Plate	GI Steel Plate	GI Steel Plate
		Base		-	GI Steel Plate	GI Steel Plate	GI Steel Plate
Heat Exchanger	Type			-	Fin & Tube	Fin & Tube	Fin & Tube
	Material	Fin		-	AL	AL	AL
		Tube		-	Cu	Cu	Cu
	Fin Treatment			-	Anti-corrosion	Anti-corrosion	Anti-corrosion
Compressor	Model Name			-	DS4BC7066FVA	DS2BD7046FVA	DS2BD7046FVA
	Quantity			EA	1	2	2
	Type			-	SCROLL_INVERTER	SCROLL_INVERTER	SCROLL_INVERTER
	Output			kW	7.17	4.95	4.95
	Oil	Type		-	POE	POE	POE
		Initial Charge		cc	1,100	900	900
Fan	Type			-	Propeller	Propeller	Propeller
	Discharge direction			-	Top discharge	Top discharge	Top discharge
	Quantity			EA	1	2	2
	Air Flow Rate			CMM	210	303	324
	External Static Pressure			Pa	110	110	110
mmAq				11	11	11	
Fan Motor	Type			-	BLDC	BLDC	BLDC
	Output			W	630	620	620
				kW	0.63	0.62	0.62

2. Specification

Standard

Model Code	Outdoor Unit		-	AM140HCVANG/EU	AM160HCVANG/EU	AM180HCVANG/EU	
	Outdoor Unit1		-	-	-	-	
	Outdoor Unit2		-	-	-	-	
	Outdoor Unit3		-	-	-	-	
	Outdoor Unit4		-	-	-	-	
Piping Connections	Liquid Pipe	Type	-	Welding	Welding	Welding	
		Diameter	mm	12.7	12.7	12.7	
	Gas Pipe	Type	-	Welding	Welding	Welding	
		Diameter	mm	22.22	28.58	28.58	
	Heat Insulation		-	Both liquid and gas pipes	Both liquid and gas pipes	Both liquid and gas pipes	
	Total piping length (System)		Max.	m	1,000	1,000	1,000
	Piping length (1st Branch-IDU)		Max.	m	90	90	90
	Piping length (ODU-IDU)		Max.	m	200	200	200
	Piping length (ODU-IDU)	Equivalent	Max.	m	220	220	220
	Level difference (IDU-IDU)		Max.	m	50	50	50
	Level difference (ODU in highest position)		Max.	m	110	110	110
	Level difference (IDU in highest position)		Max.	m	110	110	110
Wiring Connection	Transmiss on Cable	Min.	mm ²	0.75	0.75	0.75	
		Remark	-	F1, F2	F1, F2	F1, F2	
Refrigerant	Type		-	R32	R32	R32	
	Factory Charge		kg	9.3	10.2	10.2	
			tCO ₂ e	6.28	6.89	6.89	
Sound Level	Sound Pressure Level	Cooling	dB(A)	63	60	61	
		Heating	dB(A)	65	62	64	
	Sound Power Level	Cooling	dB(A)	85	81	83	
External Dimension	Net Weight		kg	214.0	271.0	271.0	
	Shipping Weight		kg	228.0	288.0	288.0	
	Net Dimensions	W x H x D	mm	930 x 1,695 x 765	1,295 x 1,695 x 765	1,295 x 1,695 x 765	
	Shipping Dimensions	W x H x D	mm	998 x 1,887 x 829	1,363 x 1,887 x 829	1,363 x 1,887 x 829	
Operating Temp. Range	Cooling	Min. ~ Max.	°C	-5 ~ 52	-5 ~ 52	-5 ~ 52	
	Heating	Min. ~ Max.	°C	-30 ~ 24	-30 ~ 24	-30 ~ 24	

NOTE

- Specification may be subject to change without prior notice.
 - Specification comply with EN14825 and Eurovent test condition.
- 1) Performances are based on the following test conditions.
 - Cooling : Indoor temperature 27°CDB, 19°CWB, Outdoor temperature 35°CDB, 24°CWB
 - Heating : Indoor temperature 20°CDB, 15°CWB, Outdoor temperature 7°CDB, 6°CWB
 - Equivalent refrigerant pipe length 5m, Level differences 0m
 - Refer to EUROVENT website(www.eurovent-certification.com) for other indoor unit combination and more detail test conditions.
 - 2) Performance of Multiple Module Outdoor unit is weighted average of Single Module outdoor units.
 - 3) Allowed combination ratio of the total rated indoor unit capacity over the rated outdoor unit capacity is 50~130%.
 - 4) Sound pressure level is obtained in an anechoic room.
 - Sound pressure level is a relative value, depending on the distance and acoustic environment.
 - Sound pressure level may differ depending on operation condition.
 - dBA = A-weighted sound pressure level
 - Reference acoustic pressure 0 dB = 20uPa
 - 5) Sound power level is an absolute value that a sound source generates.
 - dBA = A-weighted sound power level
 - Reference power : 1pW
 - Measured according to ISO 3741
 - 6) Sound values of multi combination are theoretical values based on sound results of individual installed units.
 - 7) These products contain R32 (GWP=675) which is fluorinated greenhouse gas.
 - 8) If outdoor unit is located in a higher position than indoor unit, level difference is 110m or under.
 - (If the level difference is higher than 50m, make a decision by PDM kit installation Guide software whether the PDM kit should be installed or not.)
 - PDM kit: Pressure Drop Modulation kit
 - When the outdoor unit is below the indoor unit & the level differences are 40m or more, contact your local dealer for more information.
 - 9) In case you want to know more information regarding capacity and correction, please refer to capacity table TDB on pvi.samsung.com site.
 - 10) Recommended combination

Ducted

Capacity	Indoor Units	Capacity	Indoor Units
8HP	AM056DNMFKG/EU × 4	16HP	AM071DNMFKG/EU × 6
10HP	AM071DNMFKG/EU × 4	18HP	AM071DNMFKG/EU×4 + AM056DNMFKG/EU×4
12HP	AM056DNMFKG/EU × 6	20HP	AM071DNMFKG/EU × 8
14HP	AM071DNMFKG/EU×5 + AM056DNMFKG/EU×1		

Non-Ducted

Capacity	Indoor Units	Capacity	Indoor Units
8HP	AM056DN4FKG/EU × 4	16HP	AM071DN4FKG/EU × 6
10HP	AM071DN4FKG/EU × 4	18HP	AM071DN4FKG/EU×4 + AM056DN4FKG/EU×4
12HP	AM056DN4FKG/EU × 6	20HP	AM071DN4FKG/EU × 8
14HP	AM071DN4FKG/EU×5 + AM056DN4FKG/EU×1		

2. Specification

Standard

Model Code	Outdoor Unit			-	AM200HCVANG/EU	AM220HCVANG/EU	AM240HCVANG/EU	
	Outdoor Unit1			-	-	AM100HCVANG/EU	AM100HCVANG/EU	
	Outdoor Unit2			-	-	AM120HCVANG/EU	AM140HCVANG/EU	
	Outdoor Unit3			-	-	-	-	
	Outdoor Unit4			-	-	-	-	
Power Supply				Φ # V Hz	3 4 380-415 50	3 4 380-415 50	3 4 380-415 50	
Mode				-	Heat Pump	Heat Pump	Heat Pump	
Performance	HP				20	22	24	
	kW				56.0	61.6	68.0	
	Capacity	Cooling	Rated	kW	56.0	61.6	68.0	
			Rated/Non-Ducted	kW	56.0	61.6	68.0	
		Heating	Rated	kW	63.0	69.3	76.5	
Max	kW		63.0	69.3	76.5			
Connectable indoor units	Maximum number of connectable indoor units			EA	36	40	43	
	Total capacity of the connected Indoor Units			Min.	kW	28.0	30.8	
				Max.	kW	72.8	80.1	88.4
Power	Current Input	Cooling	Rated/Ducted	A	26.42	29.46	32.90	
			Rated/Non-Ducted	A	20.64	21.95	24.60	
		Heating	Rated/Ducted	A	26.91	30.71	34.26	
			Rated/Non-Ducted	A	19.36	23.75	24.92	
	Current	Minimum Ssc			MVA	7.0	7.7	8.3
		MCA			A	43.0	48.0	52.0
		MFA			A	63	63	63
Efficiency	Cooling	SEER	Ducted	W/W	8.20	7.49	7.77	
			Non-Ducted	W/W	8.30	7.64	7.70	
		ηs,c	Ducted	%	325.00	296.60	307.80	
			Non-Ducted	%	329.00	302.60	305.00	
	Heating	SCOP	Ducted	W/W	4.80	4.35	4.47	
			Non-Ducted	W/W	5.05	4.39	4.40	
		ηs,h	Ducted	%	189.00	171.00	175.80	
			Non-Ducted	%	199.00	172.60	173.00	
			Pdesignh		kW	31.00	33.60	35.50
Casing	Material	Body		-	GI Steel Plate	GI Steel Plate	GI Steel Plate	
		Base		-	GI Steel Plate	GI Steel Plate	GI Steel Plate	
		Type		-	Fin & Tube	Fin & Tube	Fin & Tube	
Heat Exchanger	Material	Fin		-	AL	AL	AL	
		Tube		-	Cu	Cu	Cu	
	Fin Treatment			-	Anti-corrosion	Anti-corrosion	Anti-corrosion	
	Type			-	Propeller	Propeller	Propeller	
Compressor	Model Name			-	DS2BD7046FVA	(DS4BC7066FVAx1)x1 + (DS4BC7066FVAx1)x1	(DS4BC7066FVAx1)x1 + (DS4BC7066FVAx1)x1	
	Quantity			EA	2	1x1 + 1x1	1x1 + 1x1	
	Type			-	SCROLL_INVERTER	(SCROLL_INVERTERx1)x1 + (SCROLL_INVERTERx1)x1	(SCROLL_INVERTERx1)x1 + (SCROLL_INVERTERx1)x1	
	Output			kW	4.95	(7.17x1)x1 + (7.17x1)x1	(7.17x1)x1 + (7.17x1)x1	
	Oil	Type		-	POE	(POEx1)x1 + (POEx1)x1	(POEx1)x1 + (POEx1)x1	
Initial Charge		cc	900	(1,100x1)x1 + (1,100x1)x1	(1,100x1)x1 + (1,100x1)x1			
Fan	Type			-	Propeller	Propeller	Propeller	
	Discharge direction			-	Top discharge	Top discharge	Top discharge	
	Quantity			EA	2	2	2	
	Air Flow Rate			CMM	313	167x1 + 196x1	167x1 + 210x1	
	External Static Pressure			Pa	110	-	-	
mmAq				11	-	-		
Fan Motor	Type			-	BLDC	BLDC	BLDC	
	Output			W	620	(630x1)x1 + (630x1)x1	(630x1)x1 + (630x1)x1	
				kW	0.62	(0.63x1)x1 + (0.63x1)x1	(0.63x1)x1 + (0.63x1)x1	

2. Specification

Standard

Model Code	Outdoor Unit		-	AM200HCVANG/EU	AM220HCVANG/EU	AM240HCVANG/EU	
	Outdoor Unit1		-	-	AM100HCVANG/EU	AM100HCVANG/EU	
	Outdoor Unit2		-	-	AM120HCVANG/EU	AM140HCVANG/EU	
	Outdoor Unit3		-	-	-	-	
	Outdoor Unit4		-	-	-	-	
Piping Connections	Liquid Pipe	Type	-	Welding	Welding	Welding	
		Diameter	mm	12.7	12.7	12.7	
	Gas Pipe	Type	-	Welding	Welding	Welding	
		Diameter	mm	28.58	28.58	28.58	
	Heat Insulation			-	Both liquid and gas pipes	Both liquid and gas pipes	Both liquid and gas pipes
	Total piping length (System)		Max.	m	1,000	1,000	1,000
	Piping length (1st Branch-IDU)		Max.	m	90	90	90
	Piping length (ODU-IDU)		Max.	m	200	200	200
	Piping length (ODU-IDU)	Equivalent	Max.	m	220	220	220
	Level difference (IDU-IDU)		Max.	m	50	50	50
	Level difference (ODU in highest position)		Max.	m	110	110	110
	Level difference (IDU in highest position)		Max.	m	110	110	110
Wiring Connection	Transmiss on Cable	Min.	mm ²	0.75	0.75	0.75	
		Remark	-	F1, F2	F1, F2	F1, F2	
Refrigerant	Type		-	R32	R32	R32	
	Factory Charge		kg	12.5	16.3	16.3	
			tCO ₂ e	8.44	11.00	11.00	
Sound Level	Sound Pressure Level	Cooling	dB(A)	61	62	64	
		Heating	dB(A)	63	65	66	
	Sound Power Level	Cooling	dB(A)	84	83	86	
External Dimension	Net Weight		kg	293.0	193.0x1 + 214.0x1	193.0x1 + 214.0x1	
	Shipping Weight		kg	310.0	207.0x1 + 228.0x1	207.0x1 + 228.0x1	
	Net Dimensions	W x H x D	mm	1,295 x 1,695 x 765	(930 x 1,695 x 765) x 1 + (930 x 1,695 x 765) x 1	(930 x 1,695 x 765) x 1 + (930 x 1,695 x 765) x 1	
	Shipping Dimensions	W x H x D	mm	1,363 x 1,887 x 829	(998 x 1,887 x 829) x 1 + (998 x 1,887 x 829) x 1	(998 x 1,887 x 829) x 1 + (998 x 1,887 x 829) x 1	
Operating Temp. Range	Cooling	Min. ~ Max.	°C	-5 ~ 52	-5 ~ 52	-5 ~ 52	
	Heating	Min. ~ Max.	°C	-30 ~ 24	-30 ~ 24	-30 ~ 24	

NOTE

- Specification may be subject to change without prior notice.
- Specification comply with EN14825 and Eurovent test condition.
 - 1) Performances are based on the following test conditions.
 - Cooling : Indoor temperature 27°CDB, 19°CWB, Outdoor temperature 35°CDB, 24°CWB
 - Heating : Indoor temperature 20°CDB, 15°CWB, Outdoor temperature 7°CDB, 6°CWB
 - Equivalent refrigerant pipe length 5m, Level differences 0m
 - Refer to EUROVENT website(www.eurovent-certification.com) for other indoor unit combination and more detail test conditions.
 - 2) Performance of Multiple Module Outdoor unit is weighted average of Single Module outdoor units.
 - 3) Allowed combination ratio of the total rated indoor unit capacity over the rated outdoor unit capacity is 50~130%.
 - 4) Sound pressure level is obtained in an anechoic room.
 - Sound pressure level is a relative value, depending on the distance and acoustic environment.
 - Sound pressure level may differ depending on operation condition.
 - dBA = A-weighted sound pressure level
 - Reference acoustic pressure 0 dB = 20uPa
 - 5) Sound power level is an absolute value that a sound source generates.
 - dBA = A-weighted sound power level
 - Reference power : 1pW
 - Measured according to ISO 3741
 - 6) Sound values of multi combination are theoretical values based on sound results of individual installed units.
 - 7) These products contain R32 (GWP=675) which is fluorinated greenhouse gas.
 - 8) If outdoor unit is located in a higher position than indoor unit, level difference is 110m or under.
 - (If the level difference is higher than 50m, make a decision by PDM kit installation Guide software whether the PDM kit should be installed or not.)
 - PDM kit: Pressure Drop Modulation kit
 - When the outdoor unit is below the indoor unit & the level differences are 40m or more, contact your local dealer for more information.
 - 9) In case you want to know more information regarding capacity and correction, please refer to capacity table TDB on pvi.samsung.com site.
 - 10) Recommended combination

Ducted

Capacity	Indoor Units	Capacity	Indoor Units
8HP	AM056DNMFKG/EU × 4	16HP	AM071DNMFKG/EU × 6
10HP	AM071DNMFKG/EU × 4	18HP	AM071DNMFKG/EU×4 + AM056DNMFKG/EU×4
12HP	AM056DNMFKG/EU × 6	20HP	AM071DNMFKG/EU × 8
14HP	AM071DNMFKG/EU×5 + AM056DNMFKG/EU×1		

Non-Ducted

Capacity	Indoor Units	Capacity	Indoor Units
8HP	AM056DN4FKG/EU × 4	16HP	AM071DN4FKG/EU × 6
10HP	AM071DN4FKG/EU × 4	18HP	AM071DN4FKG/EU×4 + AM056DN4FKG/EU×4
12HP	AM056DN4FKG/EU × 6	20HP	AM071DN4FKG/EU × 8
14HP	AM071DN4FKG/EU×5 + AM056DN4FKG/EU×1		

2. Specification

Standard

Model Code	Outdoor Unit			-	AM260HCVANG/EU	AM280HCVANG/EU	AM300HCVANG/EU
	Outdoor Unit1			-	AM080HCVANG/EU	AM100HCVANG/EU	AM120HCVANG/EU
	Outdoor Unit2			-	AM180HCVANG/EU	AM180HCVANG/EU	AM180HCVANG/EU
	Outdoor Unit3			-	-	-	-
	Outdoor Unit4			-	-	-	-
Power Supply				Φ # V Hz	3 4 380-415 50	3 4 380-415 50	3 4 380-415 50
Mode				-	Heat Pump	Heat Pump	Heat Pump
Performance	HP				26	28	30
	kW				72.8	78.4	84.0
	Capacity	Cooling	Rated	kW	72.8	78.4	84.0
			Heating	Rated	kW	72.8	78.4
				Max	kW	81.9	88.2
Connectable indoor units	Maximum number of connectable indoor units			EA	47	51	54
	Total capacity of the connected Indoor Units		Min.	kW	36.4	39.2	42.0
			Max.	kW	94.6	101.9	109.2
Power	Current Input	Cooling	Rated/Ducted	A	35.68	38.95	40.81
			Rated/Non-Ducted	A	27.22	29.36	31.61
		Heating	Rated/Ducted	A	35.41	38.18	41.89
			Rated/Non-Ducted	A	25.96	28.35	30.80
	Current	Minimum Ssc		MVA	9.3	10.0	10.3
		MCA		A	57.2	62.2	64.2
		MFA		A	75	75	75
Efficiency	Cooling	SEER	Ducted	W/W	7.83	7.68	7.59
			Non-Ducted	W/W	7.90	7.82	7.78
		ηs,c	Ducted	%	310.20	304.20	300.60
			Non-Ducted	%	313.00	309.80	308.20
	Heating	SCOP	Ducted	W/W	4.40	4.38	4.41
			Non-Ducted	W/W	4.67	4.60	4.56
		ηs,h	Ducted	%	173.00	172.20	173.40
			Non-Ducted	%	183.80	181.00	179.40
Pdesignh			kW	40.20	41.70	44.90	
Casing	Material	Body	-	GI Steel Plate	GI Steel Plate	GI Steel Plate	
		Base	-	GI Steel Plate	GI Steel Plate	GI Steel Plate	
Heat Exchanger	Type		-	Fin & Tube	Fin & Tube	Fin & Tube	
	Material	Fin	-	AL	AL	AL	
		Tube	-	Cu	Cu	Cu	
	Fin Treatment			-	Anti-corrosion	Anti-corrosion	Anti-corrosion
Compressor	Model Name			-	(DS2BD7046FVAx1)x1 + (DS2BD7046FVAx2)x1	(DS4BC7066FVAx1)x1 + (DS2BD7046FVAx2)x1	(DS4BC7066FVAx1)x1 + (DS2BD7046FVAx2)x1
	Quantity			EA	1x1 + 2x1	1x1 + 2x1	1x1 + 2x1
	Type			-	(SCROLL_INVERTERx1)x1 + (SCROLL_INVERTERx2)x1	(SCROLL_INVERTERx1)x1 + (SCROLL_INVERTERx2)x1	(SCROLL_INVERTERx1)x1 + (SCROLL_INVERTERx2)x1
	Output			kW	(4.95x1)x1 + (4.95x2)x1	(7.17x1)x1 + (4.95x2)x1	(7.17x1)x1 + (4.95x2)x1
	Oil	Type		-	(POEx1)x1 + (POEx2)x1	(POEx1)x1 + (POEx2)x1	(POEx1)x1 + (POEx2)x1
Initial Charge		cc	(900x1)x1 + (900x2)x1	(1,100x1)x1 + (900x2)x1	(1,100x1)x1 + (900x2)x1		
Fan	Type			-	Propeller	Propeller	Propeller
	Discharge direction			-	Top discharge	Top discharge	Top discharge
	Quantity			EA	3	3	3
	Air Flow Rate			CMM	151x1 + 324x1	167x1 + 324x1	196x1 + 324x1
	External Static Pressure			Pa	-	-	-
mmAq				-	-	-	
Fan Motor	Type			-	BLDC	BLDC	BLDC
	Output			W	(630x1)x1 + (620x2)x1	(630x1)x1 + (620x2)x1	(630x1)x1 + (620x2)x1
				kW	(0.63x1)x1 + (0.62x2)x1	(0.63x1)x1 + (0.62x2)x1	(0.63x1)x1 + (0.62x2)x1

2. Specification

Standard

Model Code	Outdoor Unit		-	AM260HCVANG/EU	AM280HCVANG/EU	AM300HCVANG/EU	
	Outdoor Unit1		-	AM080HCVANG/EU	AM100HCVANG/EU	AM120HCVANG/EU	
	Outdoor Unit2		-	AM180HCVANG/EU	AM180HCVANG/EU	AM180HCVANG/EU	
	Outdoor Unit3		-	-	-	-	
	Outdoor Unit4		-	-	-	-	
Piping Connections	Liquid Pipe	Type	-	Welding	Welding	Welding	
		Diameter	mm	15.88	15.88	15.88	
	Gas Pipe	Type	-	Welding	Welding	Welding	
		Diameter	mm	28.58	28.58	34.92	
	Heat Insulation		-	Both liquid and gas pipes	Both liquid and gas pipes	Both liquid and gas pipes	
	Total piping length (System)		Max.	m	1,000	1,000	1,000
	Piping length (1st Branch-IDU)		Max.	m	90	90	90
	Piping length (ODU-IDU)		Max.	m	200	200	200
	Piping length (ODU-IDU)	Equivalent	Max.	m	220	220	220
	Level difference (IDU-IDU)		Max.	m	50	50	50
	Level difference (ODU in highest position)		Max.	m	110	110	110
Level difference (IDU in highest position)		Max.	m	110	110	110	
Wiring Connection	Transmiss on Cable	Min.	mm ²	0.75	0.75	0.75	
		Remark	-	F1, F2	F1, F2	F1, F2	
Refrigerant	Type		-	R32	R32	R32	
	Factory Charge		kg	17.2	17.2	19.5	
			tCO ₂ e	11.61	11.61	13.17	
Sound Level	Sound Pressure Level	Cooling	dB(A)	62	62	64	
		Heating	dB(A)	65	65	67	
	Sound Power Level	Cooling	dB(A)	84	84	85	
External Dimension	Net Weight		kg	183.0x1 + 271.0x1	193.0x1 + 271.0x1	214.0x1 + 271.0x1	
	Shipping Weight		kg	197.0x1 + 288.0x1	207.0x1 + 288.0x1	228.0x1 + 288.0x1	
	Net Dimensions	W x H x D	mm	(930 x 1,695 x 765) x 1 + (1,295 x 1,695 x 765) x 1	(930 x 1,695 x 765) x 1 + (1,295 x 1,695 x 765) x 1	(930 x 1,695 x 765) x 1 + (1,295 x 1,695 x 765) x 1	
	Shipping Dimensions	W x H x D	mm	(998 x 1,887 x 829) x 1 + (1,363 x 1,887 x 829) x 1	(998 x 1,887 x 829) x 1 + (1,363 x 1,887 x 829) x 1	(998 x 1,887 x 829) x 1 + (1,363 x 1,887 x 829) x 1	
Operating Temp. Range	Cooling	Min. ~ Max.	°C	-5 ~ 52	-5 ~ 52	-5 ~ 52	
	Heating	Min. ~ Max.	°C	-30 ~ 24	-30 ~ 24	-30 ~ 24	

NOTE

- Specification may be subject to change without prior notice.
- Specification comply with EN14825 and Eurovent test condition.
 - 1) Performances are based on the following test conditions.
 - Cooling : Indoor temperature 27°CDB, 19°CWB, Outdoor temperature 35°CDB, 24°CWB
 - Heating : Indoor temperature 20°CDB, 15°CWB, Outdoor temperature 7°CDB, 6°CWB
 - Equivalent refrigerant pipe length 5m, Level differences 0m
 - Refer to EUROVENT website(www.eurovent-certification.com) for other indoor unit combination and more detail test conditions.
 - 2) Performance of Multiple Module Outdoor unit is weighted average of Single Module outdoor units.
 - 3) Allowed combination ratio of the total rated indoor unit capacity over the rated outdoor unit capacity is 50~130%.
 - 4) Sound pressure level is obtained in an anechoic room.
 - Sound pressure level is a relative value, depending on the distance and acoustic environment.
 - Sound pressure level may differ depending on operation condition.
 - dBA = A-weighted sound pressure level
 - Reference acoustic pressure 0 dB = 20µPa
 - 5) Sound power level is an absolute value that a sound source generates.
 - dBA = A-weighted sound power level
 - Reference power : 1pW
 - Measured according to ISO 3741
 - 6) Sound values of multi combination are theoretical values based on sound results of individual installed units.
 - 7) These products contain R32 (GWP=675) which is fluorinated greenhouse gas.
 - 8) If outdoor unit is located in a higher position than indoor unit, level difference is 110m or under.
 - (If the level difference is higher than 50m, make a decision by PDM kit installation Guide software whether the PDM kit should be installed or not.)
 - PDM kit: Pressure Drop Modulation kit
 - When the outdoor unit is below the indoor unit & the level differences are 40m or more, contact your local dealer for more information.
 - 9) In case you want to know more information regarding capacity and correction, please refer to capacity table TDB on pvi.samsung.com site.
 - 10) Recommended combination

Ducted

Capacity	Indoor Units	Capacity	Indoor Units
8HP	AM056DNMFKG/EU × 4	16HP	AM071DNMFKG/EU × 6
10HP	AM071DNMFKG/EU × 4	18HP	AM071DNMFKG/EU×4 + AM056DNMFKG/EU×4
12HP	AM056DNMFKG/EU × 6	20HP	AM071DNMFKG/EU × 8
14HP	AM071DNMFKG/EU×5 + AM056DNMFKG/EU×1		

Non-Ducted

Capacity	Indoor Units	Capacity	Indoor Units
8HP	AM056DN4FKG/EU × 4	16HP	AM071DN4FKG/EU × 6
10HP	AM071DN4FKG/EU × 4	18HP	AM071DN4FKG/EU×4 + AM056DN4FKG/EU×4
12HP	AM056DN4FKG/EU × 6	20HP	AM071DN4FKG/EU × 8
14HP	AM071DN4FKG/EU×5 + AM056DN4FKG/EU×1		

2. Specification

Standard

Model Code	Outdoor Unit			-	AM320HCVANG/EU	AM340HCVANG/EU	AM360HCVANG/EU
	Outdoor Unit1			-	AM140HCVANG/EU	AM160HCVANG/EU	AM180HCVANG/EU
	Outdoor Unit2			-	AM180HCVANG/EU	AM180HCVANG/EU	AM180HCVANG/EU
	Outdoor Unit3			-	-	-	-
	Outdoor Unit4			-	-	-	-
Power Supply				Φ # V Hz	3 4 380-415 50	3 4 380-415 50	3 4 380-415 50
Mode				-	Heat Pump	Heat Pump	Heat Pump
Performance	HP				32	34	36
	kW				90.4	95.4	100.8
	Capacity	Cooling	Rated	kW	90.4	95.4	100.8
			Heating	Rated	kW	90.4	95.4
				Max	kW	101.7	107.1
Connectable indoor units	Maximum number of connectable indoor units			EA	58	61	64
	Total capacity of the connected Indoor Units		Min.	kW	45.2	47.7	50.4
			Max.	kW	117.5	124.0	131.0
Power	Current Input	Cooling	Rated/Ducted	A	44.25	48.74	50.30
			Rated/Non-Ducted	A	34.26	36.42	39.02
		Heating	Rated/Ducted	A	45.44	49.36	49.36
			Rated/Non-Ducted	A	31.97	34.09	35.40
	Current	Minimum Ssc		MVA	10.9	11.5	12.6
		MCA		A	68.2	71.2	78.4
		MFA		A	80	90	90
Efficiency	Cooling	SEER	Ducted	W/W	7.80	7.87	7.73
			Non-Ducted	W/W	7.81	8.15	7.90
		ηs,c	Ducted	%	309.00	311.80	306.20
			Non-Ducted	%	309.40	323.00	313.00
	Heating	SCOP	Ducted	W/W	4.50	4.56	4.43
			Non-Ducted	W/W	4.56	4.79	4.70
		ηs,h	Ducted	%	177.00	179.40	174.20
			Non-Ducted	%	179.40	188.60	185.00
			Pdesignh		kW	46.80	49.70
Casing	Material	Body	-	GI Steel Plate	GI Steel Plate	GI Steel Plate	
		Base	-	GI Steel Plate	GI Steel Plate	GI Steel Plate	
		Type	-	Fin & Tube	Fin & Tube	Fin & Tube	
Heat Exchanger	Material	Fin	-	AL	AL	AL	
		Tube	-	Cu	Cu	Cu	
		Fin Treatment	-	Anti-corrosion	Anti-corrosion	Anti-corrosion	
Compressor	Model Name			-	(DS4BC7066FVAx1)x1 + (DS2BD7046FVAx2)x1	(DS2BD7046FVAx2)x1 + (DS2BD7046FVAx2)x1	(DS2BD7046FVAx2)x2
	Quantity			EA	1x1 + 2x1	2x1 + 2x1	2x2
	Type			-	(SCROLL_INVERTERx1)x1 + (SCROLL_INVERTERx2)x1	(SCROLL_INVERTERx2)x1 + (SCROLL_INVERTERx2)x1	(SCROLL_INVERTERx2)x2
	Output			kW	(7.17x1)x1 + (4.95x2)x1	(4.95x2)x1 + (4.95x2)x1	(4.95x2)x2
	Oil	Type		-	(POEx1)x1 + (POEx2)x1	(POEx2)x1 + (POEx2)x1	(POEx2)x2
Initial Charge		cc	(1,100x1)x1 + (900x2)x1	(900x2)x1 + (900x2)x1	(900x2)x2		
Fan	Type			-	Propeller	Propeller	Propeller
	Discharge direction			-	Top discharge	Top discharge	Top discharge
	Quantity			EA	3	4	4
	Air Flow Rate			CMM	210x1 + 324x1	303x1 + 324x1	324x2
	External Static Pressure			Pa	-	-	-
mmAq				-	-	-	
Fan Motor	Type			-	BLDC	BLDC	BLDC
	Output			W	(630x1)x1 + (620x2)x1	(620x2)x1 + (620x2)x1	(620x2)x2
				kW	(0.63x1)x1 + (0.62x2)x1	(0.62x2)x1 + (0.62x2)x1	(0.62x2)x2

2. Specification

Standard

Model Code	Outdoor Unit		-	AM320HCVANG/EU	AM340HCVANG/EU	AM360HCVANG/EU	
	Outdoor Unit1		-	AM140HCVANG/EU	AM160HCVANG/EU	AM180HCVANG/EU	
	Outdoor Unit2		-	AM180HCVANG/EU	AM180HCVANG/EU	AM180HCVANG/EU	
	Outdoor Unit3		-	-	-	-	
	Outdoor Unit4		-	-	-	-	
Piping Connections	Liquid Pipe	Type	-	Welding	Welding	Welding	
		Diameter	mm	15.88	15.88	15.88	
	Gas Pipe	Type	-	Welding	Welding	Welding	
		Diameter	mm	34.92	34.92	34.92	
	Heat Insulation		-	Both liquid and gas pipes	Both liquid and gas pipes	Both liquid and gas pipes	
	Total piping length (System)		Max.	m	1,000	1,000	1,000
	Piping length (1st Branch-IDU)		Max.	m	90	90	90
	Piping length (ODU-IDU)		Max.	m	200	200	200
	Piping length (ODU-IDU)	Equivalent	Max.	m	220	220	220
	Level difference (IDU-IDU)		Max.	m	50	50	50
	Level difference (ODU in highest position)		Max.	m	110	110	110
	Level difference (IDU in highest position)		Max.	m	110	110	110
Wiring Connection	Transmiss on Cable	Min.	mm ²	0.75	0.75	0.75	
		Remark	-	F1, F2	F1, F2	F1, F2	
Refrigerant	Type		-	R32	R32	R32	
	Factory Charge		kg	19.5	20.4	20.4	
			tCO ₂ e	13.17	13.78	13.78	
Sound Level	Sound Pressure Level	Cooling	dB(A)	65	64	64	
		Heating	dB(A)	68	66	67	
	Sound Power Level	Cooling	dB(A)	87	85	86	
External Dimension	Net Weight		kg	214.0x1 + 271.0x1	271.0x1 + 271.0x1	271.0x2	
	Shipping Weight		kg	228.0x1 + 288.0x1	288.0x1 + 288.0x1	288.0x2	
	Net Dimensions	W x H x D	mm	(930 x 1,695 x 765) x 1 + (1,295 x 1,695 x 765) x 1	(1,295 x 1,695 x 765) x 1 + (1,295 x 1,695 x 765) x 1	(1,295 x 1,695 x 765) x 2	
	Shipping Dimensions	W x H x D	mm	(998 x 1,887 x 829) x 1 + (1,363 x 1,887 x 829) x 1	(1,363 x 1,887 x 829) x 1 + (1,363 x 1,887 x 829) x 1	(1,363 x 1,887 x 829) x 2	
Operating Temp. Range	Cooling	Min. ~ Max.	°C	-5 ~ 52	-5 ~ 52	-5 ~ 52	
	Heating	Min. ~ Max.	°C	-30 ~ 24	-30 ~ 24	-30 ~ 24	

NOTE

- Specification may be subject to change without prior notice.
- Specification comply with EN14825 and Eurovent test condition.
 - 1) Performances are based on the following test conditions.
 - Cooling : Indoor temperature 27°CDB, 19°CWB, Outdoor temperature 35°CDB, 24°CWB
 - Heating : Indoor temperature 20°CDB, 15°CWB, Outdoor temperature 7°CDB, 6°CWB
 - Equivalent refrigerant pipe length 5m, Level differences 0m
 - Refer to EUROVENT website(www.eurovent-certification.com) for other indoor unit combination and more detail test conditions.
 - 2) Performance of Multiple Module Outdoor unit is weighted average of Single Module outdoor units.
 - 3) Allowed combination ratio of the total rated indoor unit capacity over the rated outdoor unit capacity is 50~130%.
 - 4) Sound pressure level is obtained in an anechoic room.
 - Sound pressure level is a relative value, depending on the distance and acoustic environment.
 - Sound pressure level may differ depending on operation condition.
 - dBA = A-weighted sound pressure level
 - Reference acoustic pressure 0 dB = 20uPa
 - 5) Sound power level is an absolute value that a sound source generates.
 - dBA = A-weighted sound power level
 - Reference power : 1pW
 - Measured according to ISO 3741
 - 6) Sound values of multi combination are theoretical values based on sound results of individual installed units.
 - 7) These products contain R32 (GWP=675) which is fluorinated greenhouse gas.
 - 8) If outdoor unit is located in a higher position than indoor unit, level difference is 110m or under.
 - (If the level difference is higher than 50m, make a decision by PDM kit installation Guide software whether the PDM kit should be installed or not.)
 - PDM kit: Pressure Drop Modulation kit
 - When the outdoor unit is below the indoor unit & the level differences are 40m or more, contact your local dealer for more information.
 - 9) In case you want to know more information regarding capacity and correction, please refer to capacity table TDB on pvi.samsung.com site.
 - 10) Recommended combination

Ducted

Capacity	Indoor Units	Capacity	Indoor Units
8HP	AM056DNMFKG/EU x 4	16HP	AM071DNMFKG/EU x 6
10HP	AM071DNMFKG/EU x 4	18HP	AM071DNMFKG/EU x 4 + AM056DNMFKG/EU x 4
12HP	AM056DNMFKG/EU x 6	20HP	AM071DNMFKG/EU x 8
14HP	AM071DNMFKG/EU x 5 + AM056DNMFKG/EU x 1		

Non-Ducted

Capacity	Indoor Units	Capacity	Indoor Units
8HP	AM056DN4FKG/EU x 4	16HP	AM071DN4FKG/EU x 6
10HP	AM071DN4FKG/EU x 4	18HP	AM071DN4FKG/EU x 4 + AM056DN4FKG/EU x 4
12HP	AM056DN4FKG/EU x 6	20HP	AM071DN4FKG/EU x 8
14HP	AM071DN4FKG/EU x 5 + AM056DN4FKG/EU x 1		

2. Specification

Standard

Model Code	Outdoor Unit			-	AM380HCVANG/EU	AM400HCVANG/EU	AM420HCVANG/EU
	Outdoor Unit1			-	AM180HCVANG/EU	AM200HCVANG/EU	AM120HCVANG/EU
	Outdoor Unit2			-	AM200HCVANG/EU	AM200HCVANG/EU	AM120HCVANG/EU
	Outdoor Unit3			-	-	-	AM180HCVANG/EU
	Outdoor Unit4			-	-	-	-
Power Supply				Φ # V Hz	3 4 380-415 50	3 4 380-415 50	3 4 380-415 50
Mode				-	Heat Pump	Heat Pump	Heat Pump
Performance	HP				38	40	42
	kW				106.4	112.0	117.6
	Capacity	Cooling	Rated	kW	106.4	112.0	117.6
			Heating	Rated	kW	106.4	112.0
				Max	kW	119.7	126.0
Connectable indoor units	Maximum number of connectable indoor units			EA	64	64	64
	Total capacity of the connected Indoor Units		Min.	kW	53.2	56.0	58.8
			Max.	kW	138.3	145.6	152.9
Power	Current Input	Cooling	Rated/Ducted	A	51.57	52.84	56.47
			Rated/Non-Ducted	A	40.15	41.28	43.71
		Heating	Rated/Ducted	A	51.59	53.82	59.10
			Rated/Non-Ducted	A	37.06	38.72	43.90
	Current	Minimum Ssc		MVA	13.3	14.0	14.3
		MCA		A	82.2	86.0	89.2
		MFA		A	100	100	125
Efficiency	Cooling	SEER	Ducted	W/W	7.97	8.20	7.54
			Non-Ducted	W/W	8.11	8.30	7.72
		ηs,c	Ducted	%	315.80	325.00	298.60
			Non-Ducted	%	321.40	329.00	305.80
	Heating	SCOP	Ducted	W/W	4.62	4.80	4.41
			Non-Ducted	W/W	4.88	5.05	4.51
		ηs,h	Ducted	%	181.80	189.00	173.40
			Non-Ducted	%	192.20	199.00	177.40
		Pdesignh	kW	57.50	62.00	63.30	
Casing	Material	Body	-	GI Steel Plate	GI Steel Plate	GI Steel Plate	
		Base	-	GI Steel Plate	GI Steel Plate	GI Steel Plate	
Heat Exchanger	Type		-	Fin & Tube	Fin & Tube	Fin & Tube	
	Material	Fin	-	AL	AL	AL	
		Tube	-	Cu	Cu	Cu	
	Fin Treatment		-	Anti-corrosion	Anti-corrosion	Anti-corrosion	
Compressor	Model Name		-	(DS2BD7046FVAx2)x1 + (DS2BD7046FVAx2)x1	(DS2BD7046FVAx2)x2	(DS4BC7066FVAx1)x2 + (DS2BD7046FVAx2)x1	
	Quantity		EA	2x1 + 2x1	2x2	1x2 + 2x1	
	Type		-	(SCROLL_INVERTERx2)x1 + (SCROLL_INVERTERx2)x1	(SCROLL_INVERTERx2)x2	(SCROLL_INVERTERx1)x2 + (SCROLL_INVERTERx2)x1	
	Output		kW	(4.95x2)x1 + (4.95x2)x1	(4.95x2)x2	(7.17x1)x2 + (4.95x2)x1	
	Oil	Type	-	(POEx2)x1 + (POEx2)x1	(POEx2)x2	(POEx1)x2 + (POEx2)x1	
Initial Charge		cc	(900x2)x1 + (900x2)x1	(900x2)x2	(1,100x1)x2 + (900x2)x1		
Fan	Type		-	Propeller	Propeller	Propeller	
	Discharge direction		-	Top discharge	Top discharge	Top discharge	
	Quantity		EA	4	4	4	
	Air Flow Rate		CMM	324x1 + 313x1	313x2	196x2 + 324x1	
	External Static Pressure		Pa	-	-	-	
mmAq			-	-	-		
Fan Motor	Type		-	BLDC	BLDC	BLDC	
	Output		W	(620x2)x1 + (620x2)x1	(620x2)x2	(630x1)x2 + (620x2)x1	
			kW	(0.62x2)x1 + (0.62x2)x1	(0.62x2)x2	(0.63x1)x2 + (0.62x2)x1	

2. Specification

Standard

Model Code	Outdoor Unit		-	AM380HCVANG/EU	AM400HCVANG/EU	AM420HCVANG/EU	
	Outdoor Unit1		-	AM180HCVANG/EU	AM200HCVANG/EU	AM120HCVANG/EU	
	Outdoor Unit2		-	AM200HCVANG/EU	AM200HCVANG/EU	AM120HCVANG/EU	
	Outdoor Unit3		-	-	-	AM180HCVANG/EU	
	Outdoor Unit4		-	-	-	-	
Piping Connections	Liquid Pipe	Type	-	Welding	Welding	Welding	
		Diameter	mm	15.88	15.88	15.88	
	Gas Pipe	Type	-	Welding	Welding	Welding	
		Diameter	mm	34.92	34.92	34.92	
	Heat Insulation		-	Both liquid and gas pipes	Both liquid and gas pipes	Both liquid and gas pipes	
	Total piping length (System)		Max.	m	1,000	1,000	1,000
	Piping length (1st Branch-IDU)		Max.	m	90	90	90
	Piping length (ODU-IDU)		Max.	m	200	200	200
	Piping length (ODU-IDU)	Equivalent	Max.	m	220	220	220
	Level difference (IDU-IDU)		Max.	m	50	50	50
	Level difference (ODU in highest position)		Max.	m	110	110	110
Level difference (IDU in highest position)		Max.	m	110	110	110	
Wiring Connection	Transmiss on Cable	Min.	mm ²	0.75	0.75	0.75	
		Remark	-	F1, F2	F1, F2	F1, F2	
Refrigerant	Type		-	R32	R32	R32	
	Factory Charge		kg	22.7	25.0	28.8	
			tCO ₂ e	15.33	16.88	19.45	
Sound Level	Sound Pressure Level	Cooling	dB(A)	64	64	66	
		Heating	dB(A)	67	66	68	
	Sound Power Level	Cooling	dB(A)	87	87	87	
External Dimension	Net Weight		kg	271.0x1 + 293.0x1	293.0x2	214.0x2 + 271.0x1	
	Shipping Weight		kg	288.0x1 + 310.0x1	310.0x2	228.0x2 + 288.0x1	
	Net Dimensions	W x H x D	mm	(1,295 x 1,695 x 765) x 1 + (1,295 x 1,695 x 765) x 1	(1,295 x 1,695 x 765) x 2	(930 x 1,695 x 765) x 2 + (1,295 x 1,695 x 765) x 1	
	Shipping Dimensions	W x H x D	mm	(1,363 x 1,887 x 829) x 1 + (1,363 x 1,887 x 829) x 1	(1,363 x 1,887 x 829) x 2	(998 x 1,887 x 829) x 2 + (1,363 x 1,887 x 829) x 1	
Operating Temp. Range	Cooling	Min. ~ Max.	°C	-5 ~ 52	-5 ~ 52	-5 ~ 52	
	Heating	Min. ~ Max.	°C	-30 ~ 24	-30 ~ 24	-30 ~ 24	

NOTE

- Specification may be subject to change without prior notice.
- Specification comply with EN14825 and Eurovent test condition.
 - 1) Performances are based on the following test conditions.
 - Cooling : Indoor temperature 27°CDB, 19°CWB, Outdoor temperature 35°CDB, 24°CWB
 - Heating : Indoor temperature 20°CDB, 15°CWB, Outdoor temperature 7°CDB, 6°CWB
 - Equivalent refrigerant pipe length 5m, Level differences 0m
 - Refer to EUROVENT website(www.eurovent-certification.com) for other indoor unit combination and more detail test conditions.
 - 2) Performance of Multiple Module Outdoor unit is weighted average of Single Module outdoor units.
 - 3) Allowed combination ratio of the total rated indoor unit capacity over the rated outdoor unit capacity is 50-130%.
 - 4) Sound pressure level is obtained in an anechoic room.
 - Sound pressure level is a relative value, depending on the distance and acoustic environment.
 - Sound pressure level may differ depending on operation condition.
 - dBA = A-weighted sound pressure level
 - Reference acoustic pressure 0 dB = 20uPa
 - 5) Sound power level is an absolute value that a sound source generates.
 - dBA = A-weighted sound power level
 - Reference power : 1pW
 - Measured according to ISO 3741
 - 6) Sound values of multi combination are theoretical values based on sound results of individual installed units.
 - 7) These products contain R32 (GWP=675) which is fluorinated greenhouse gas.
 - 8) If outdoor unit is located in a higher position than indoor unit, level difference is 110m or under.
 - (If the level difference is higher than 50m, make a decision by PDM kit installation Guide software whether the PDM kit should be installed or not.)
 - PDM kit: Pressure Drop Modulation kit
 - When the outdoor unit is below the indoor unit & the level differences are 40m or more, contact your local dealer for more information.
 - 9) In case you want to know more information regarding capacity and correction, please refer to capacity table TDB on pvi.samsung.com site.
 - 10) Recommended combination

Ducted

Capacity	Indoor Units	Capacity	Indoor Units
8HP	AM056DNMFKG/EU x 4	16HP	AM071DNMFKG/EU x 6
10HP	AM071DNMFKG/EU x 4	18HP	AM071DNMFKG/EU x 4 + AM056DNMFKG/EU x 4
12HP	AM056DNMFKG/EU x 6	20HP	AM071DNMFKG/EU x 8
14HP	AM071DNMFKG/EU x 5 + AM056DNMFKG/EU x 1		

Non-Ducted

Capacity	Indoor Units	Capacity	Indoor Units
8HP	AM056DN4FKG/EU x 4	16HP	AM071DN4FKG/EU x 6
10HP	AM071DN4FKG/EU x 4	18HP	AM071DN4FKG/EU x 4 + AM056DN4FKG/EU x 4
12HP	AM056DN4FKG/EU x 6	20HP	AM071DN4FKG/EU x 8
14HP	AM071DN4FKG/EU x 5 + AM056DN4FKG/EU x 1		

2. Specification

Standard

Model Code	Outdoor Unit			-	AM440HCVANG/EU	AM460HCVANG/EU	AM480HCVANG/EU
	Outdoor Unit1			-	AM080HCVANG/EU	AM100HCVANG/EU	AM120HCVANG/EU
	Outdoor Unit2			-	AM180HCVANG/EU	AM180HCVANG/EU	AM180HCVANG/EU
	Outdoor Unit3			-	AM180HCVANG/EU	AM180HCVANG/EU	AM180HCVANG/EU
	Outdoor Unit4			-	-	-	-
Power Supply			Φ # V Hz	3 4 380-415 50	3 4 380-415 50	3 4 380-415 50	
Mode			-	Heat Pump	Heat Pump	Heat Pump	
Performance	HP				44	46	48
	kW				123.2	128.8	134.4
	Capacity	Cooling	Rated	kW	123.2	128.8	134.4
			Heating	Rated	kW	123.2	128.8
		Max	kW	138.6	144.9	151.2	
Connectable indoor units	Maximum number of connectable indoor units			EA	64	64	64
	Total capacity of the connected Indoor Units		Min.	kW	61.6	64.4	67.2
			Max.	kW	160.1	167.4	174.7
Power	Current Input	Cooling	Rated/Ducted	A	60.83	64.10	65.96
			Rated/Non-Ducted	A	46.73	48.87	51.12
		Heating	Rated/Ducted	A	60.09	62.86	66.57
			Rated/Non-Ducted	A	43.66	46.05	48.50
	Current	Minimum Ssc		MVA	15.6	16.3	16.6
		MCA		A	96.4	101.4	103.4
		MFA		A	125	125	125
Efficiency	Cooling	SEER	Ducted	W/W	7.79	7.70	7.64
			Non-Ducted	W/W	7.90	7.85	7.82
		ηs,c	Ducted	%	308.60	305.00	302.60
			Non-Ducted	%	313.00	311.00	309.80
	Heating	SCOP	Ducted	W/W	4.41	4.40	4.42
			Non-Ducted	W/W	4.68	4.63	4.61
		ηs,h	Ducted	%	173.40	173.00	173.80
			Non-Ducted	%	184.20	182.20	181.40
			Pdesignh		kW	66.70	68.20
Casing	Material	Body	-	GI Steel Plate	GI Steel Plate	GI Steel Plate	
		Base	-	GI Steel Plate	GI Steel Plate	GI Steel Plate	
Heat Exchanger	Type		-	Fin & Tube	Fin & Tube	Fin & Tube	
	Material	Fin	-	AL	AL	AL	
		Tube	-	Cu	Cu	Cu	
	Fin Treatment		-	Anti-corrosion	Anti-corrosion	Anti-corrosion	
Compressor	Model Name		-	(DS2BD7046FVAx1)x1 + (DS2BD7046FVAx2)x2	(DS4BC7066FVAx1)x1 + (DS2BD7046FVAx2)x2	(DS4BC7066FVAx1)x1 + (DS2BD7046FVAx2)x2	
	Quantity		EA	1x1 + 2x2	1x1 + 2x2	1x1 + 2x2	
	Type		-	(SCROLL_INVERTERx1)x1 + (SCROLL_INVERTERx2)x2	(SCROLL_INVERTERx1)x1 + (SCROLL_INVERTERx2)x2	(SCROLL_INVERTERx1)x1 + (SCROLL_INVERTERx2)x2	
	Output		kW	(4.95x1)x1 + (4.95x2)x2	(7.17x1)x1 + (4.95x2)x2	(7.17x1)x1 + (4.95x2)x2	
	Oil	Type		-	(POEx1)x1 + (POEx2)x2	(POEx1)x1 + (POEx2)x2	(POEx1)x1 + (POEx2)x2
		Initial Charge		cc	(900x1)x1 + (900x2)x2	(1,100x1)x1 + (900x2)x2	(1,100x1)x1 + (900x2)x2
Fan	Type		-	Propeller	Propeller	Propeller	
	Discharge direction		-	Top discharge	Top discharge	Top discharge	
	Quantity		EA	5	5	5	
	Air Flow Rate		CMM	151x1 + 324x2	167x1 + 324x2	196x1 + 324x2	
	External Static Pressure		Pa	-	-	-	
mmAq			-	-	-		
Fan Motor	Type		-	BLDC	BLDC	BLDC	
	Output		W	(630x1)x1 + (620x2)x2	(630x1)x1 + (620x2)x2	(630x1)x1 + (620x2)x2	
			kW	(0.63x1)x1 + (0.62x2)x2	(0.63x1)x1 + (0.62x2)x2	(0.63x1)x1 + (0.62x2)x2	

2. Specification

Standard

Model Code	Outdoor Unit		-	AM440HCVANG/EU	AM460HCVANG/EU	AM480HCVANG/EU	
	Outdoor Unit1		-	AM080HCVANG/EU	AM100HCVANG/EU	AM120HCVANG/EU	
	Outdoor Unit2		-	AM180HCVANG/EU	AM180HCVANG/EU	AM180HCVANG/EU	
	Outdoor Unit3		-	AM180HCVANG/EU	AM180HCVANG/EU	AM180HCVANG/EU	
	Outdoor Unit4		-	-	-	-	
Piping Connections	Liquid Pipe	Type	-	Welding	Welding	Welding	
		Diameter	mm	19.05	19.05	19.05	
	Gas Pipe	Type	-	Welding	Welding	Welding	
		Diameter	mm	41.28	41.28	41.28	
	Heat Insulation		-	Both liquid and gas pipes	Both liquid and gas pipes	Both liquid and gas pipes	
	Total piping length (System)		Max.	m	1,000	1,000	1,000
	Piping length (1st Branch-IDU)		Max.	m	90	90	90
	Piping length (ODU-IDU)		Max.	m	200	200	200
	Piping length (ODU-IDU)	Equivalent	Max.	m	220	220	220
	Level difference (IDU-IDU)		Max.	m	50	50	50
	Level difference (ODU in highest position)		Max.	m	110	110	110
	Level difference (IDU in highest position)		Max.	m	110	110	110
Wiring Connection	Transmiss on Cable	Min.	mm ²	0.75	0.75	0.75	
		Remark	-	F1, F2	F1, F2	F1, F2	
Refrigerant	Type		-	R32	R32	R32	
	Factory Charge		kg	27.4	27.4	29.7	
			tCO ₂ e	18.51	18.51	20.06	
Sound Level	Sound Pressure Level	Cooling	dB(A)	64	65	66	
		Heating	dB(A)	68	68	68	
	Sound Power Level	Cooling	dB(A)	86	87	87	
External Dimension	Net Weight		kg	183.0x1 + 271.0x2	193.0x1 + 271.0x2	214.0x1 + 271.0x2	
	Shipping Weight		kg	197.0x1 + 288.0x2	207.0x1 + 288.0x2	228.0x1 + 288.0x2	
	Net Dimensions	W x H x D	mm	(930 x 1,695 x 765) x 1 + (1,295 x 1,695 x 765) x 2	(930 x 1,695 x 765) x 1 + (1,295 x 1,695 x 765) x 2	(930 x 1,695 x 765) x 1 + (1,295 x 1,695 x 765) x 2	
	Shipping Dimensions	W x H x D	mm	(998 x 1,887 x 829) x 1 + (1,363 x 1,887 x 829) x 2	(998 x 1,887 x 829) x 1 + (1,363 x 1,887 x 829) x 2	(998 x 1,887 x 829) x 1 + (1,363 x 1,887 x 829) x 2	
Operating Temp. Range	Cooling	Min. ~ Max.	°C	-5 ~ 52	-5 ~ 52	-5 ~ 52	
	Heating	Min. ~ Max.	°C	-30 ~ 24	-30 ~ 24	-30 ~ 24	

NOTE

- Specification may be subject to change without prior notice.
- Specification comply with EN14825 and Eurovent test condition.
 - 1) Performances are based on the following test conditions.
 - Cooling : Indoor temperature 27°CDB, 19°CWB, Outdoor temperature 35°CDB, 24°CWB
 - Heating : Indoor temperature 20°CDB, 15°CWB, Outdoor temperature 7°CDB, 6°CWB
 - Equivalent refrigerant pipe length 5m, Level differences 0m
 - Refer to EUROVENT website(www.eurovent-certification.com) for other indoor unit combination and more detail test conditions.
 - 2) Performance of Multiple Module Outdoor unit is weighted average of Single Module outdoor units.
 - 3) Allowed combination ratio of the total rated indoor unit capacity over the rated outdoor unit capacity is 50~130%.
 - 4) Sound pressure level is obtained in an anechoic room.
 - Sound pressure level is a relative value, depending on the distance and acoustic environment.
 - Sound pressure level may differ depending on operation condition.
 - dBA = A-weighted sound pressure level
 - Reference acoustic pressure 0 dB = 20uPa
 - 5) Sound power level is an absolute value that a sound source generates.
 - dBA = A-weighted sound power level
 - Reference power : 1pW
 - Measured according to ISO 3741
 - 6) Sound values of multi combination are theoretical values based on sound results of individual installed units.
 - 7) These products contain R32 (GWP=675) which is fluorinated greenhouse gas.
 - 8) If outdoor unit is located in a higher position than indoor unit, level difference is 110m or under.
 - (If the level difference is higher than 50m, make a decision by PDM kit installation Guide software whether the PDM kit should be installed or not.)
 - PDM kit: Pressure Drop Modulation kit
 - When the outdoor unit is below the indoor unit & the level differences are 40m or more, contact your local dealer for more information.
 - 9) In case you want to know more information regarding capacity and correction, please refer to capacity table TDB on pvi.samsung.com site.
 - 10) Recommended combination

Ducted

Capacity	Indoor Units	Capacity	Indoor Units
8HP	AM056DNMFKG/EU x 4	16HP	AM071DNMFKG/EU x 6
10HP	AM071DNMFKG/EU x 4	18HP	AM071DNMFKG/EU x 4 + AM056DNMFKG/EU x 4
12HP	AM056DNMFKG/EU x 6	20HP	AM071DNMFKG/EU x 8
14HP	AM071DNMFKG/EU x 5 + AM056DNMFKG/EU x 1		

Non-Ducted

Capacity	Indoor Units	Capacity	Indoor Units
8HP	AM056DN4FKG/EU x 4	16HP	AM071DN4FKG/EU x 6
10HP	AM071DN4FKG/EU x 4	18HP	AM071DN4FKG/EU x 4 + AM056DN4FKG/EU x 4
12HP	AM056DN4FKG/EU x 6	20HP	AM071DN4FKG/EU x 8
14HP	AM071DN4FKG/EU x 5 + AM056DN4FKG/EU x 1		

2. Specification

Standard

Model Code	Outdoor Unit			-	AM500HCVANG/EU	AM520HCVANG/EU	AM540HCVANG/EU
	Outdoor Unit1			-	AM140HCVANG/EU	AM160HCVANG/EU	AM180HCVANG/EU
	Outdoor Unit2			-	AM180HCVANG/EU	AM180HCVANG/EU	AM180HCVANG/EU
	Outdoor Unit3			-	AM180HCVANG/EU	AM180HCVANG/EU	AM180HCVANG/EU
	Outdoor Unit4			-	-	-	-
Power Supply				Φ # V Hz	3 4 380-415 50	3 4 380-415 50	3 4 380-415 50
Mode				-	Heat Pump	Heat Pump	Heat Pump
Performance	HP				50	52	54
	kW				140.8	145.8	151.2
	Capacity	Cooling	Rated	kW	140.8	145.8	151.2
			Heating	Rated	kW	140.8	145.8
		Max	kW	158.4	163.8	170.1	
Connectable indoor units	Maximum number of connectable indoor units			EA	64	64	64
	Total capacity of the connected Indoor Units		Min.	kW	70.4	72.9	75.6
			Max.	kW	183.0	189.5	196.5
Power	Current Input	Cooling	Rated/Ducted	A	69.40	73.89	75.45
			Rated/Non-Ducted	A	53.77	55.93	58.53
		Heating	Rated/Ducted	A	70.12	74.04	74.04
			Rated/Non-Ducted	A	49.67	51.79	53.10
	Current	Minimum Ssc		MVA	17.2	17.8	18.9
		MCA		A	107.4	110.4	117.6
		MFA		A	150	150	150
Efficiency	Cooling	SEER	Ducted	W/W	7.77	7.82	7.73
			Non-Ducted	W/W	7.84	8.06	7.90
		ηs,c	Ducted	%	307.80	309.80	306.20
			Non-Ducted	%	310.60	319.40	313.00
	Heating	SCOP	Ducted	W/W	4.47	4.51	4.43
			Non-Ducted	W/W	4.61	4.76	4.70
		ηs,h	Ducted	%	175.80	177.40	174.20
			Non-Ducted	%	181.40	187.40	185.00
Pdesignh			kW	73.30	76.20	79.50	
Casing	Material	Body		-	GI Steel Plate	GI Steel Plate	GI Steel Plate
		Base		-	GI Steel Plate	GI Steel Plate	GI Steel Plate
Heat Exchanger	Type			-	Fin & Tube	Fin & Tube	Fin & Tube
	Material	Fin		-	AL	AL	AL
		Tube		-	Cu	Cu	Cu
	Fin Treatment			-	Anti-corrosion	Anti-corrosion	Anti-corrosion
Compressor	Model Name			-	(DS4BC7066FVAx1)x1 + (DS2BD7046FVAx2)x2	(DS2BD7046FVAx2)x1 + (DS2BD7046FVAx2)x2	(DS2BD7046FVAx2)x3
	Quantity			EA	1x1 + 2x2	2x1 + 2x2	2x3
	Type			-	(SCROLL_INVERTERx1)x1 + (SCROLL_INVERTERx2)x2	(SCROLL_INVERTERx2)x1 + (SCROLL_INVERTERx2)x2	(SCROLL_INVERTERx2)x3
	Output			kW	(7.17x1)x1 + (4.95x2)x2	(4.95x2)x1 + (4.95x2)x2	(4.95x2)x3
	Oil	Type		-	(POEx1)x1 + (POEx2)x2	(POEx2)x1 + (POEx2)x2	(POEx2)x3
Initial Charge		cc	(1,100x1)x1 + (900x2)x2	(900x2)x1 + (900x2)x2	(900x2)x3		
Fan	Type			-	Propeller	Propeller	Propeller
	Discharge direction			-	Top discharge	Top discharge	Top discharge
	Quantity			EA	5	6	6
	Air Flow Rate			CMM	210x1 + 324x2	303x1 + 324x2	324x3
	External Static Pressure			Pa	-	-	-
mmAq				-	-	-	
Fan Motor	Type			-	BLDC	BLDC	BLDC
	Output			W	(630x1)x1 + (620x2)x2	(620x2)x1 + (620x2)x2	(620x2)x3
				kW	(0.63x1)x1 + (0.62x2)x2	(0.62x2)x1 + (0.62x2)x2	(0.62x2)x3

2. Specification

Standard

Model Code	Outdoor Unit		-	AM500HCVANG/EU	AM520HCVANG/EU	AM540HCVANG/EU	
	Outdoor Unit1		-	AM140HCVANG/EU	AM160HCVANG/EU	AM180HCVANG/EU	
	Outdoor Unit2		-	AM180HCVANG/EU	AM180HCVANG/EU	AM180HCVANG/EU	
	Outdoor Unit3		-	AM180HCVANG/EU	AM180HCVANG/EU	AM180HCVANG/EU	
	Outdoor Unit4		-	-	-	-	
Piping Connections	Liquid Pipe	Type	-	Welding	Welding	Welding	
		Diameter	mm	19.05	19.05	19.05	
	Gas Pipe	Type	-	Welding	Welding	Welding	
		Diameter	mm	41.28	41.28	41.28	
	Heat Insulation		-	Both liquid and gas pipes	Both liquid and gas pipes	Both liquid and gas pipes	
	Total piping length (System)		Max.	m	1,000	1,000	1,000
	Piping length (1st Branch-IDU)		Max.	m	90	90	90
	Piping length (ODU-IDU)		Max.	m	200	200	200
	Piping length (ODU-IDU)	Equivalent	Max.	m	220	220	220
	Level difference (IDU-IDU)		Max.	m	50	50	50
	Level difference (ODU in highest position)		Max.	m	110	110	110
	Level difference (IDU in highest position)		Max.	m	110	110	110
Wiring Connection	Transmiss on Cable	Min.	mm ²	0.75	0.75	0.75	
		Remark	-	F1, F2	F1, F2	F1, F2	
Refrigerant	Type		-	R32	R32	R32	
	Factory Charge		kg	29.7	30.6	30.6	
			tCO ₂ e	20.06	20.67	20.67	
Sound Level	Sound Pressure Level	Cooling	dB(A)	67	65	66	
		Heating	dB(A)	69	68	69	
	Sound Power Level	Cooling	dB(A)	89	87	88	
External Dimension	Net Weight		kg	214.0x1 + 271.0x2	271.0x1 + 271.0x2	271.0x3	
	Shipping Weight		kg	228.0x1 + 288.0x2	288.0x1 + 288.0x2	288.0x3	
	Net Dimensions	W x H x D	mm	(930 x 1,695 x 765) x 1 + (1,295 x 1,695 x 765) x 2	(1,295 x 1,695 x 765) x 1 + (1,295 x 1,695 x 765) x 2	(1,295 x 1,695 x 765) x 3	
	Shipping Dimensions	W x H x D	mm	(998 x 1,887 x 829) x 1 + (1,363 x 1,887 x 829) x 2	(1,363 x 1,887 x 829) x 1 + (1,363 x 1,887 x 829) x 2	(1,363 x 1,887 x 829) x 3	
Operating Temp. Range	Cooling	Min. ~ Max.	°C	-5 ~ 52	-5 ~ 52	-5 ~ 52	
	Heating	Min. ~ Max.	°C	-30 ~ 24	-30 ~ 24	-30 ~ 24	

NOTE

- Specification may be subject to change without prior notice.
- Specification comply with EN14825 and Eurovent test condition.
 - 1) Performances are based on the following test conditions.
 - Cooling : Indoor temperature 27°CDB, 19°CWB, Outdoor temperature 35°CDB, 24°CWB
 - Heating : Indoor temperature 20°CDB, 15°CWB, Outdoor temperature 7°CDB, 6°CWB
 - Equivalent refrigerant pipe length 5m, Level differences 0m
 - Refer to EUROVENT website(www.eurovent-certification.com) for other indoor unit combination and more detail test conditions.
 - 2) Performance of Multiple Module Outdoor unit is weighted average of Single Module outdoor units.
 - 3) Allowed combination ratio of the total rated indoor unit capacity over the rated outdoor unit capacity is 50~130%.
 - 4) Sound pressure level is obtained in an anechoic room.
 - Sound pressure level is a relative value, depending on the distance and acoustic environment.
 - Sound pressure level may differ depending on operation condition.
 - dBA = A-weighted sound pressure level
 - Reference acoustic pressure 0 dB = 20uPa
 - 5) Sound power level is an absolute value that a sound source generates.
 - dBA = A-weighted sound power level
 - Reference power : 1pW
 - Measured according to ISO 3741
 - 6) Sound values of multi combination are theoretical values based on sound results of individual installed units.
 - 7) These products contain R32 (GWP=675) which is fluorinated greenhouse gas.
 - 8) If outdoor unit is located in a higher position than indoor unit, level difference is 110m or under.
 - (If the level difference is higher than 50m, make a decision by PDM kit installation Guide software whether the PDM kit should be installed or not.)
 - PDM kit: Pressure Drop Modulation kit
 - When the outdoor unit is below the indoor unit & the level differences are 40m or more, contact your local dealer for more information.
 - 9) In case you want to know more information regarding capacity and correction, please refer to capacity table TDB on pvi.samsung.com site.
 - 10) Recommended combination

Ducted

Capacity	Indoor Units	Capacity	Indoor Units
8HP	AM056DNMFKG/EU x 4	16HP	AM071DNMFKG/EU x 6
10HP	AM071DNMFKG/EU x 4	18HP	AM071DNMFKG/EU x 4 + AM056DNMFKG/EU x 4
12HP	AM056DNMFKG/EU x 6	20HP	AM071DNMFKG/EU x 8
14HP	AM071DNMFKG/EU x 5 + AM056DNMFKG/EU x 1		

Non-Ducted

Capacity	Indoor Units	Capacity	Indoor Units
8HP	AM056DN4FKG/EU x 4	16HP	AM071DN4FKG/EU x 6
10HP	AM071DN4FKG/EU x 4	18HP	AM071DN4FKG/EU x 4 + AM056DN4FKG/EU x 4
12HP	AM056DN4FKG/EU x 6	20HP	AM071DN4FKG/EU x 8
14HP	AM071DN4FKG/EU x 5 + AM056DN4FKG/EU x 1		

2. Specification

Standard

Model Code	Outdoor Unit			-	AM560HCVANG/EU	AM580HCVANG/EU	AM600HCVANG/EU
	Outdoor Unit1			-	AM180HCVANG/EU	AM180HCVANG/EU	AM200HCVANG/EU
	Outdoor Unit2			-	AM180HCVANG/EU	AM200HCVANG/EU	AM200HCVANG/EU
	Outdoor Unit3			-	AM200HCVANG/EU	AM200HCVANG/EU	AM200HCVANG/EU
	Outdoor Unit4			-	-	-	-
Power Supply				Φ # V Hz	3 4 380-415 50	3 4 380-415 50	3 4 380-415 50
Mode				-	Heat Pump	Heat Pump	Heat Pump
Performance	HP				56	58	60
	kW				156.8	162.4	168.0
	Capacity	Cooling	Rated	kW	156.8	162.4	168.0
			Rated	kW	156.8	162.4	168.0
		Heating	Max	kW	176.4	182.7	189.0
Maximum number of connectable indoor units			EA	64	64	64	
Connectable indoor units	Total capacity of the connected Indoor Units		Min.	kW	78.4	81.2	84.0
			Max.	kW	203.8	211.1	218.4
Power	Current Input	Cooling	Rated/Ducted	A	76.72	77.99	79.26
			Rated/Non-Ducted	A	59.66	60.79	61.92
		Heating	Rated/Ducted	A	76.27	78.50	80.73
			Rated/Non-Ducted	A	54.76	56.42	58.08
	Current	Minimum Ssc		MVA	19.6	20.3	21.0
		MCA		A	121.4	125.2	129.0
		MFA		A	150	150	150
Efficiency	Cooling	SEER	Ducted	W/W	7.89	8.05	8.20
			Non-Ducted	W/W	8.04	8.17	8.30
		ηs,c	Ducted	%	312.60	319.00	325.00
			Non-Ducted	%	318.60	323.80	329.00
	Heating	SCOP	Ducted	W/W	4.56	4.68	4.80
			Non-Ducted	W/W	4.82	4.94	5.05
		ηs,h	Ducted	%	179.40	184.20	189.00
			Non-Ducted	%	189.80	194.60	199.00
Pdesignh			kW	84.00	88.50	93.00	
Casing	Material	Body	-	GI Steel Plate	GI Steel Plate	GI Steel Plate	
		Base	-	GI Steel Plate	GI Steel Plate	GI Steel Plate	
Heat Exchanger	Type		-	Fin & Tube	Fin & Tube	Fin & Tube	
	Material	Fin	-	AL	AL	AL	
		Tube	-	Cu	Cu	Cu	
	Fin Treatment			-	Anti-corrosion	Anti-corrosion	Anti-corrosion
Compressor	Model Name			-	(DS2BD7046FVAx2)x2 + (DS2BD7046FVAx2)x1	(DS2BD7046FVAx2)x1 + (DS2BD7046FVAx2)x2	(DS2BD7046FVAx2)x3
	Quantity			EA	2x2 + 2x1	2x1 + 2x2	2x3
	Type			-	(SCROLL_INVERTERx2)x2 + (SCROLL_INVERTERx2)x1	(SCROLL_INVERTERx2)x1 + (SCROLL_INVERTERx2)x2	(SCROLL_INVERTERx2)x3
	Output			kW	(4.95x2)x2 + (4.95x2)x1	(4.95x2)x1 + (4.95x2)x2	(4.95x2)x3
	Oil	Type		-	(POEx2)x2 + (POEx2)x1	(POEx2)x1 + (POEx2)x2	(POEx2)x3
Initial Charge		cc	(900x2)x2 + (900x2)x1	(900x2)x1 + (900x2)x2	(900x2)x3		
Fan	Type			-	Propeller	Propeller	Propeller
	Discharge direction			-	Top discharge	Top discharge	Top discharge
	Quantity			EA	6	6	6
	Air Flow Rate			CMM	324x2 + 313x1	324x1 + 313x2	313x3
	External Static Pressure			Pa	-	-	-
mmAq				-	-	-	
Fan Motor	Type			-	BLDC	BLDC	BLDC
	Output			W	(620x2)x2 + (620x2)x1	(620x2)x1 + (620x2)x2	(620x2)x3
				kW	(0.62x2)x2 + (0.62x2)x1	(0.62x2)x1 + (0.62x2)x2	(0.62x2)x3

2. Specification

Standard

Model Code	Outdoor Unit		-	AM560HCVANG/EU	AM580HCVANG/EU	AM600HCVANG/EU	
	Outdoor Unit1		-	AM180HCVANG/EU	AM180HCVANG/EU	AM200HCVANG/EU	
	Outdoor Unit2		-	AM180HCVANG/EU	AM200HCVANG/EU	AM200HCVANG/EU	
	Outdoor Unit3		-	AM200HCVANG/EU	AM200HCVANG/EU	AM200HCVANG/EU	
	Outdoor Unit4		-	-	-	-	
Piping Connections	Liquid Pipe	Type	-	Welding	Welding	Welding	
		Diameter	mm	19.05	19.05	19.05	
	Gas Pipe	Type	-	Welding	Welding	Welding	
		Diameter	mm	41.28	41.28	41.28	
	Heat Insulation		-	Both liquid and gas pipes	Both liquid and gas pipes	Both liquid and gas pipes	
	Total piping length (System)		Max.	m	1,000	1,000	1,000
	Piping length (1st Branch-IDU)		Max.	m	90	90	90
	Piping length (ODU-IDU)		Max.	m	200	200	200
	Piping length (ODU-IDU)	Equivalent	Max.	m	220	220	220
	Level difference (IDU-IDU)		Max.	m	50	50	50
	Level difference (ODU in highest position)		Max.	m	110	110	110
Level difference (IDU in highest position)		Max.	m	110	110	110	
Wiring Connection	Transmiss on Cable	Min.	mm ²	0.75	0.75	0.75	
		Remark	-	F1, F2	F1, F2	F1, F2	
Refrigerant	Type		-	R32	R32	R32	
	Factory Charge		kg	32.9	35.2	37.5	
			tCO ₂ e	22.22	23.77	25.32	
Sound Level	Sound Pressure Level	Cooling	dB(A)	66	66	66	
		Heating	dB(A)	68	68	68	
	Sound Power Level	Cooling	dB(A)	88	88	89	
External Dimension	Net Weight		kg	271.0x2 + 293.0x1	271.0x1 + 293.0x2	293.0x3	
	Shipping Weight		kg	288.0x2 + 310.0x1	288.0x1 + 310.0x2	310.0x3	
	Net Dimensions	W x H x D	mm	(1,295 x 1,695 x 765) x 2 + (1,295 x 1,695 x 765) x 1	(1,295 x 1,695 x 765) x 1 + (1,295 x 1,695 x 765) x 2	(1,295 x 1,695 x 765) x 3	
	Shipping Dimensions	W x H x D	mm	(1,363 x 1,887 x 829) x 2 + (1,363 x 1,887 x 829) x 1	(1,363 x 1,887 x 829) x 1 + (1,363 x 1,887 x 829) x 2	(1,363 x 1,887 x 829) x 3	
Operating Temp. Range	Cooling	Min. ~ Max.	°C	-5 ~ 52	-5 ~ 52	-5 ~ 52	
	Heating	Min. ~ Max.	°C	-30 ~ 24	-30 ~ 24	-30 ~ 24	

NOTE

- Specification may be subject to change without prior notice.
- Specification comply with EN14825 and Eurovent test condition.
 - 1) Performances are based on the following test conditions.
 - Cooling : Indoor temperature 27°CDB, 19°CWB, Outdoor temperature 35°CDB, 24°CWB
 - Heating : Indoor temperature 20°CDB, 15°CWB, Outdoor temperature 7°CDB, 6°CWB
 - Equivalent refrigerant pipe length 5m, Level differences 0m
 - Refer to EUROVENT website(www.eurovent-certification.com) for other indoor unit combination and more detail test conditions.
 - 2) Performance of Multiple Module Outdoor unit is weighted average of Single Module outdoor units.
 - 3) Allowed combination ratio of the total rated indoor unit capacity over the rated outdoor unit capacity is 50~130%.
 - 4) Sound pressure level is obtained in an anechoic room.
 - Sound pressure level is a relative value, depending on the distance and acoustic environment.
 - Sound pressure level may differ depending on operation condition.
 - dBA = A-weighted sound pressure level
 - Reference acoustic pressure 0 dB = 20uPa
 - 5) Sound power level is an absolute value that a sound source generates.
 - dBA = A-weighted sound power level
 - Reference power : 1pW
 - Measured according to ISO 3741
 - 6) Sound values of multi combination are theoretical values based on sound results of individual installed units.
 - 7) These products contain R32 (GWP=675) which is fluorinated greenhouse gas.
 - 8) If outdoor unit is located in a higher position than indoor unit, level difference is 110m or under.
 - (If the level difference is higher than 50m, make a decision by PDM kit installation Guide software whether the PDM kit should be installed or not.)
 - PDM kit: Pressure Drop Modulation kit
 - When the outdoor unit is below the indoor unit & the level differences are 40m or more, contact your local dealer for more information.
 - 9) In case you want to know more information regarding capacity and correction, please refer to capacity table TDB on pvi.samsung.com site.
 - 10) Recommended combination

Ducted

Capacity	Indoor Units	Capacity	Indoor Units
8HP	AM056DNMFKG/EU x 4	16HP	AM071DNMFKG/EU x 6
10HP	AM071DNMFKG/EU x 4	18HP	AM071DNMFKG/EU x 4 + AM056DNMFKG/EU x 4
12HP	AM056DNMFKG/EU x 6	20HP	AM071DNMFKG/EU x 8
14HP	AM071DNMFKG/EU x 5 + AM056DNMFKG/EU x 1		

Non-Ducted

Capacity	Indoor Units	Capacity	Indoor Units
8HP	AM056DN4FKG/EU x 4	16HP	AM071DN4FKG/EU x 6
10HP	AM071DN4FKG/EU x 4	18HP	AM071DN4FKG/EU x 4 + AM056DN4FKG/EU x 4
12HP	AM056DN4FKG/EU x 6	20HP	AM071DN4FKG/EU x 8
14HP	AM071DN4FKG/EU x 5 + AM056DN4FKG/EU x 1		

3. Summary Table

Standard

Electric Characteristics

Capacity		Model Code	Power Supply				Voltage Range		Current Input(A)		Current(A)		Fan Motor	
HP	kW		Φ	#	Hz	V	Min.	Max.	Cooling	Heating	MCA	MFA	kW	FLA[A]
8	22.4	AM080HCVANG/EU	3	4	50	380-415	342	457	10.53	10.73	18.0	25	0.63	4.60
10	28.0	AM100HCVANG/EU	3	4	50	380-415	342	457	13.80	13.50	23.0	32	0.63	4.60
12	33.6	AM120HCVANG/EU	3	4	50	380-415	342	457	15.66	17.21	25.0	32	0.63	4.60
14	40.0	AM140HCVANG/EU	3	4	50	380-415	342	457	19.10	20.76	29.0	32	0.63	4.20
16	45.0	AM160HCVANG/EU	3	4	50	380-415	342	457	23.59	24.68	32.0	40	1.24	4.20
18	50.4	AM180HCVANG/EU	3	4	50	380-415	342	457	25.15	24.68	39.2	50	1.24	4.20
20	56.0	AM200HCVANG/EU	3	4	50	380-415	342	457	26.42	26.91	43.0	63	1.24	4.20
22	61.6	AM220HCVANG/EU	3	4	50	380-415	342	457	29.46	30.71	48.0	63	1.26	9.20
24	68.0	AM240HCVANG/EU	3	4	50	380-415	342	457	32.90	34.26	52.0	63	1.26	8.80
26	72.8	AM260HCVANG/EU	3	4	50	380-415	342	457	35.68	35.41	57.2	75	1.87	8.80
28	78.4	AM280HCVANG/EU	3	4	50	380-415	342	457	38.95	38.18	62.2	75	1.87	8.80
30	84.0	AM300HCVANG/EU	3	4	50	380-415	342	457	40.81	41.89	64.2	75	1.87	8.80
32	90.4	AM320HCVANG/EU	3	4	50	380-415	342	457	44.25	45.44	68.2	80	1.87	8.40
34	95.4	AM340HCVANG/EU	3	4	50	380-415	342	457	48.74	49.36	71.2	90	2.48	8.40
36	100.8	AM360HCVANG/EU	3	4	50	380-415	342	457	50.30	49.36	78.4	90	2.48	8.40
38	106.4	AM380HCVANG/EU	3	4	50	380-415	342	457	51.57	51.59	82.2	100	2.48	8.40
40	112.0	AM400HCVANG/EU	3	4	50	380-415	342	457	52.84	53.82	86.0	100	2.48	8.40
42	117.6	AM420HCVANG/EU	3	4	50	380-415	342	457	56.47	59.10	89.2	125	2.50	13.40
44	123.2	AM440HCVANG/EU	3	4	50	380-415	342	457	60.83	60.09	96.4	125	3.11	13.00
46	128.8	AM460HCVANG/EU	3	4	50	380-415	342	457	64.10	62.86	101.4	125	3.11	13.00
48	134.4	AM480HCVANG/EU	3	4	50	380-415	342	457	65.96	66.57	103.4	125	3.11	13.00
50	140.8	AM500HCVANG/EU	3	4	50	380-415	342	457	69.40	70.12	107.4	150	3.11	12.60
52	145.8	AM520HCVANG/EU	3	4	50	380-415	342	457	73.89	74.04	110.4	150	3.72	12.60
54	151.2	AM540HCVANG/EU	3	4	50	380-415	342	457	75.45	74.04	117.6	150	3.72	12.60
56	156.8	AM560HCVANG/EU	3	4	50	380-415	342	457	76.72	76.27	121.4	150	3.72	12.60
58	162.4	AM580HCVANG/EU	3	4	50	380-415	342	457	77.99	78.50	125.2	150	3.72	12.60
60	168.0	AM600HCVANG/EU	3	4	50	380-415	342	457	79.26	80.73	129.0	150	3.72	12.60

NOTE

- MCA : Minimum circuit amperes (A)
- MFA : Maximum fuse amperes (A)
- FLA : Full load amperes
- Select wire size based on the value of MCA

4. Dimensional Drawing

DVM S2+

AM080HCVANG/EU, AM100HCVANG/EU

Unit: mm [inch]

SECTION B-B

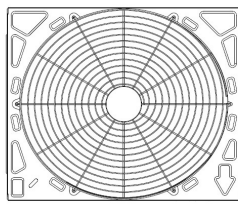
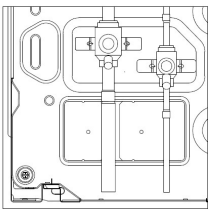

DETAIL A

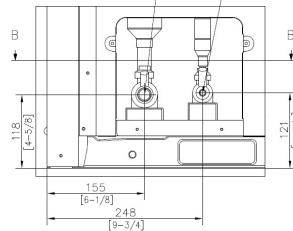

NOTE

1. Detail A and SECTION B-B indicate the dimension after fixing the attached piping.
2. Item 3-6 : Knock-out hole
3. View C indicate the dimension of knock-out hole(bottom)
4. Pipe [Φ, mm(inch)] : Brazing connection

HP	Liquid pipe	Gas pipe
8	9.52(3/8)	19.05(3/4)
10	9.52(3/8)	22.22(7/8)
12	12.70(1/2)	28.58(1-1/8)
14	12.70(1/2)	28.58(1-1/8)
16	12.70(1/2)	28.58(1-1/8)
18	15.88(5/8)	28.58(1-1/8)
20	15.88(5/8)	28.58(1-1/8)
22	15.88(5/8)	28.58(1-1/8)
24	15.88(5/8)	34.92(1-3/8)
26	19.05(3/4)	34.92(1-3/8)

VIEW C

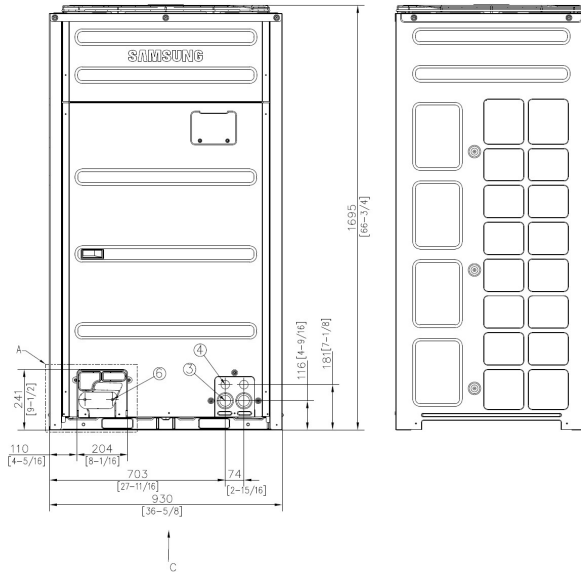
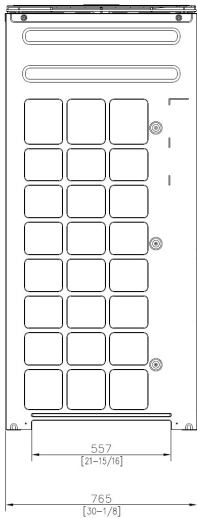
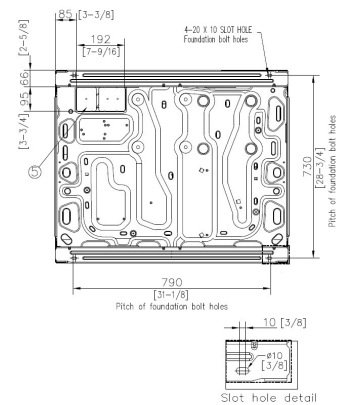

No.	Name	Description	
		AM080HCVANG	AM100HCVANG
1	Gas pipe connection	19.05 [3/4]	22.22 [7/8]
2	Liquid pipe connection	9.52 [3/8]	
3	Power supply wiring conduit	-	
4	Communication wiring conduit	-	
5	Piping intake knockout hole	Bottom	
6	Piping intake knockout hole	Front	

4. Dimensional Drawing

DVM S2+

AM120HCVANG/EU, AM140HCVANG/EU

Unit: mm [inch]

SECTION B-B

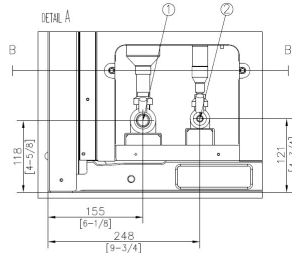
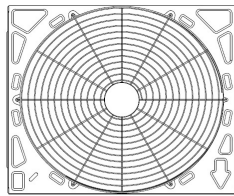
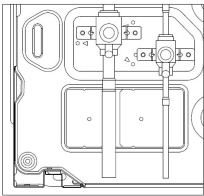

NOTE

1. Detail A and SECTION B-B indicate the dimension after fixing the attached piping.
2. Item 3-6 : Knock-out hole
3. View C indicate the dimension of knock-out hole(bottom)
4. Pipe [Ø, mm(inch)] : Brazing connection

HP	Liquid pipe	Gas pipe
8	9.52(3/8)	19.05(3/4)
10	9.52(3/8)	22.22(7/8)
12	12.70(1/2)	28.58(1-1/8)
14	12.70(1/2)	28.58(1-1/8)
16	12.70(1/2)	28.58(1-1/8)
18	15.88(5/8)	28.58(1-1/8)
20	15.88(5/8)	28.58(1-1/8)
22	15.88(5/8)	28.58(1-1/8)
24	15.88(5/8)	34.92(1-3/8)
26	19.05(3/4)	34.92(1-3/8)

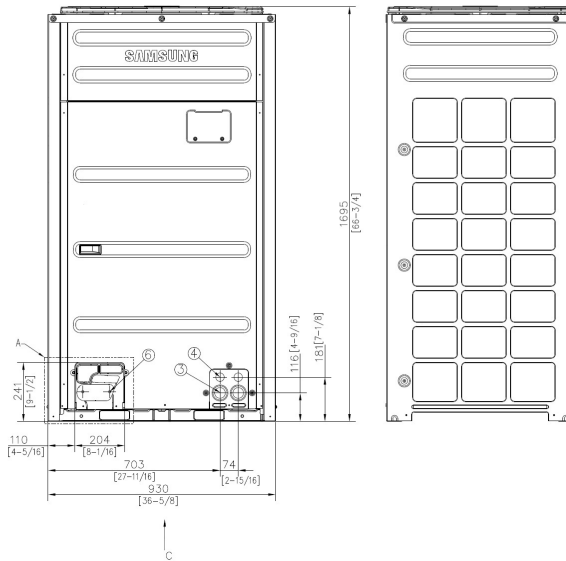
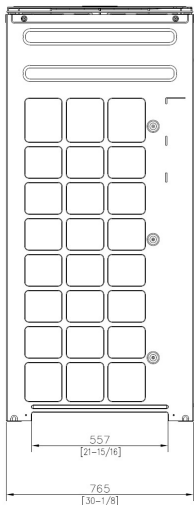

VIEW C

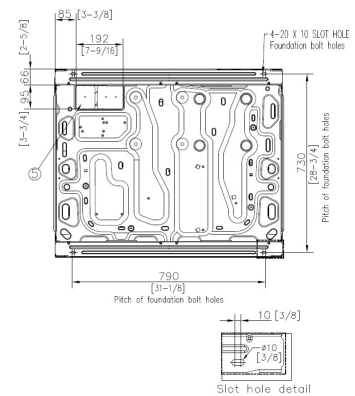

No.	Name	Description
1	Gas pipe connection	22.22 [7/8]
2	Liquid pipe connection	12.7 [1/2]
3	Power supply wiring conduit	-
4	Communication wiring conduit	-
5	Piping intake knockout hole	Bottom
6	Piping intake knockout hole	Front

4. Dimensional Drawing

DVM S2+

AM160HCVANG/EU, AM180HCVANG/EU, AM200HCVANG/EU

Unit: mm [inch]

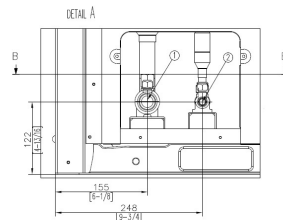
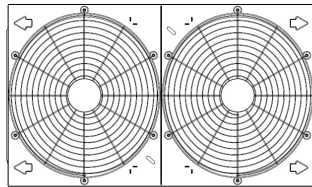
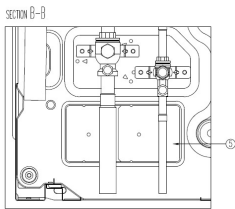

- NOTE**
1. Detail A and SECTION B-B indicate the dimension after fixing the attached piping.
 2. Item 3-5 : Knock-out hole
 3. View C indicate the dimension of knock-out hole(bottom)
 4. Pipe [φ, mm(inch)] : Brazing connection

HP	Liquid pipe	Gas pipe
8	9.52(3/8)	19.05(3/4)
10	9.52(3/8)	22.22(7/8)
12	12.70(1/2)	28.58(1-1/8)
14	12.70(1/2)	28.58(1-1/8)
16	12.70(1/2)	28.58(1-1/8)
18	15.88(5/8)	28.58(1-1/8)
20	15.88(5/8)	28.58(1-1/8)
22	15.88(5/8)	28.58(1-1/8)
24	15.88(5/8)	34.92(1-3/8)
26	19.05(3/4)	34.92(1-3/8)

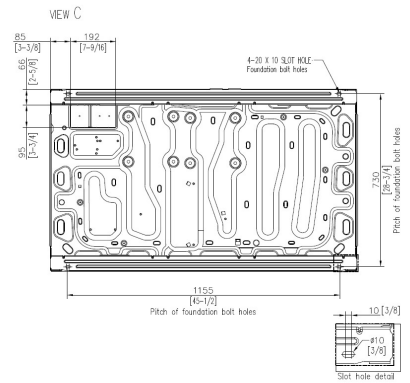
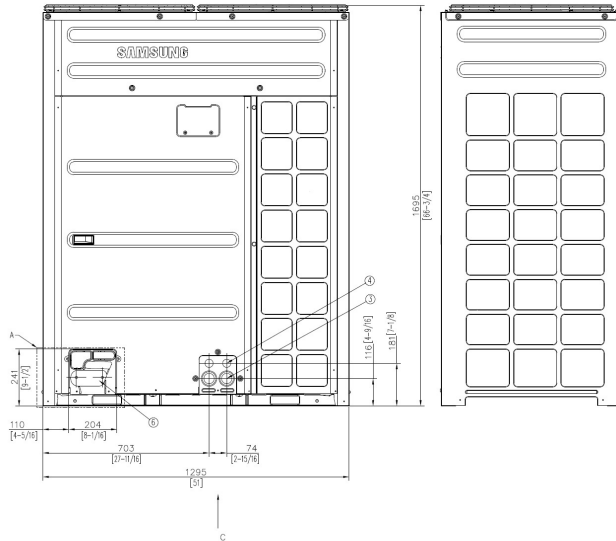
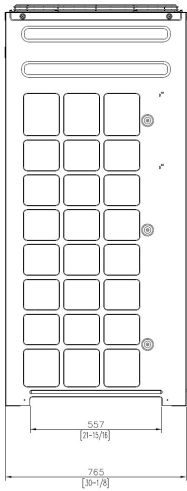

No.	Name	Description
1	Gas pipe connection	28.58 [1-1/8]
2	Liquid pipe connection	12.7 [1/2]
3	Power supply wiring conduit	-
4	Communication wiring conduit	-
5	Piping intake knockout hole	-
6	Piping intake knockout hole	-

5. Center of Gravity

DVM S2+

AM080HCVANG/EU, AM100HCVANG/EU

Unit: mm [inch]

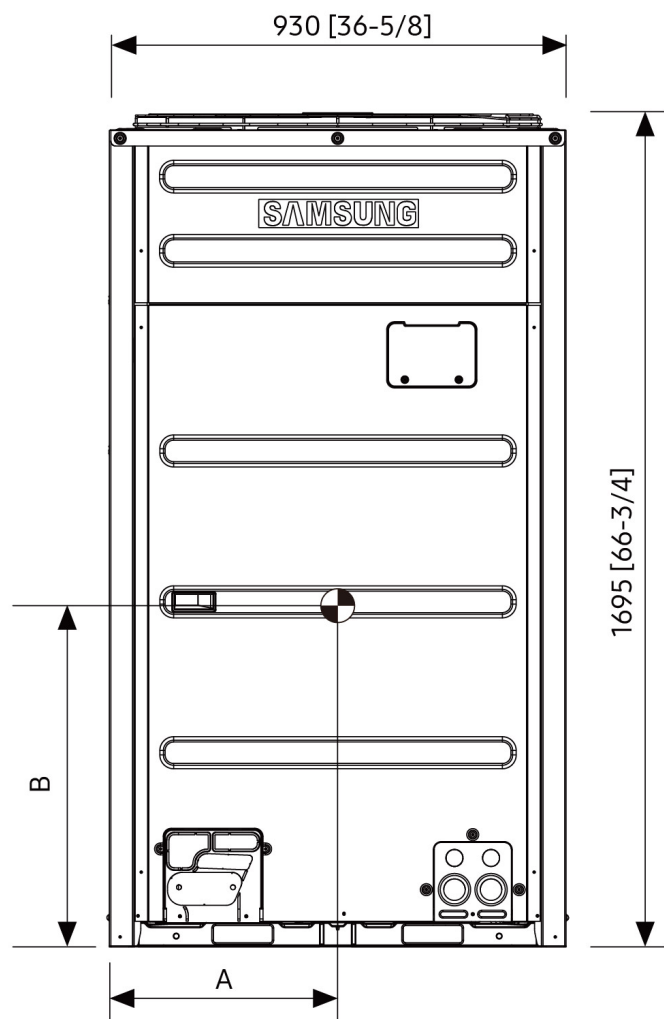
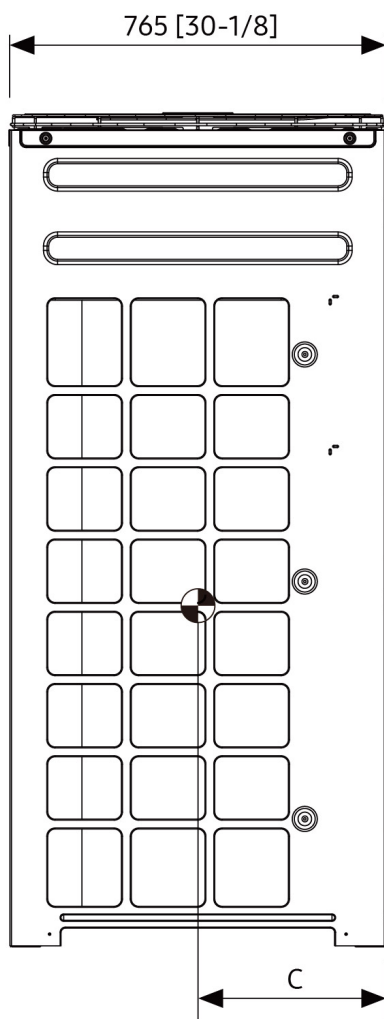

Model	A	B	C
AM080HCVANG/EU	460 [18-1/8]	716 [28-3/16]	348 [13-11/16]
AM100HCVANG/EU	458 [18-1/16]	694 [27-5/16]	340 [13-3/8]

5. Center of Gravity

DVM S2+

AM120HCVANG/EU, AM140HCVANG/EU

Unit: mm [inch]

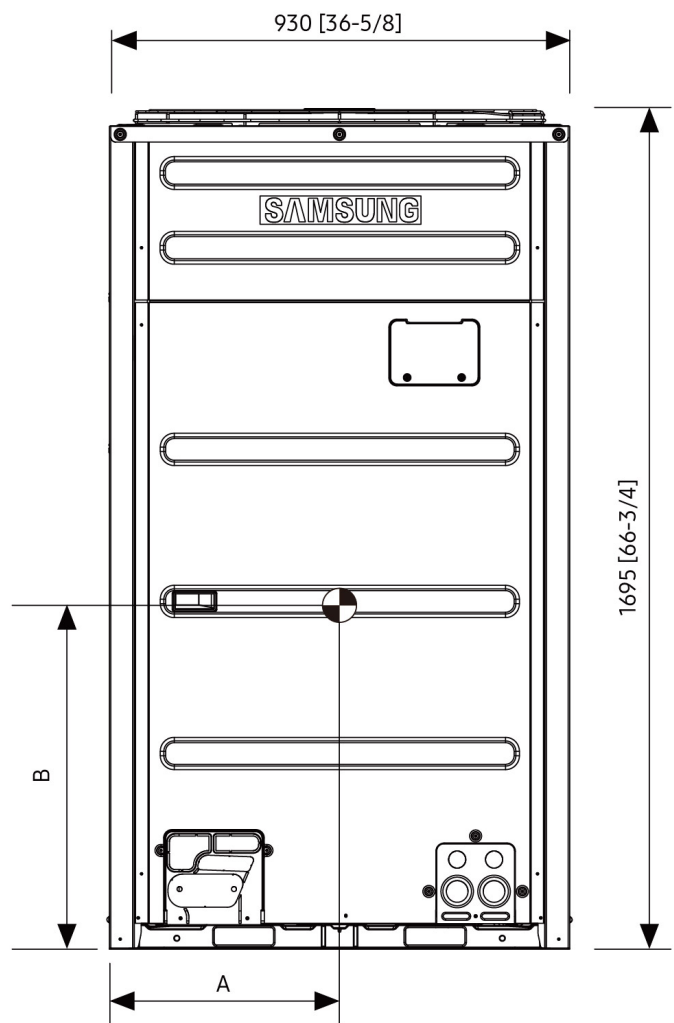
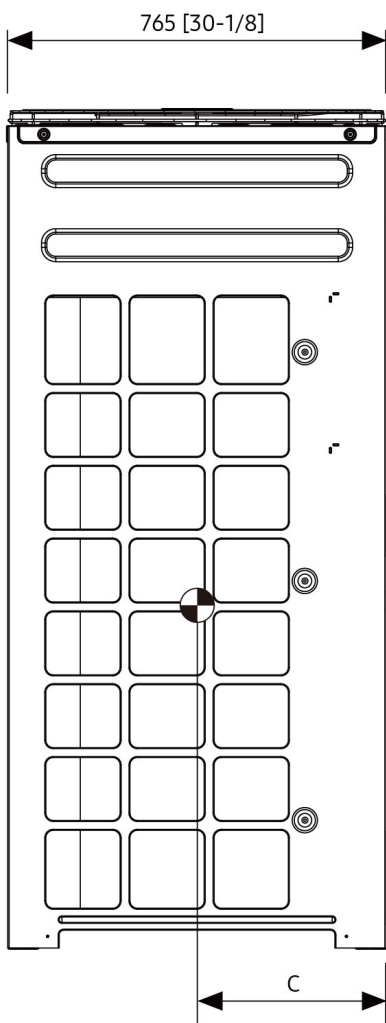

Model	A	B	C
AM120HCVANG/EU AM140HCVANG/EU	461 [18-1/8]	694 [27-5/16]	351 [13-13/16]

5. Center of Gravity

DVM S2+

AM160HCVANG/EU, AM180HCVANG/EU, AM200HCVANG/EU

Unit: mm [inch]

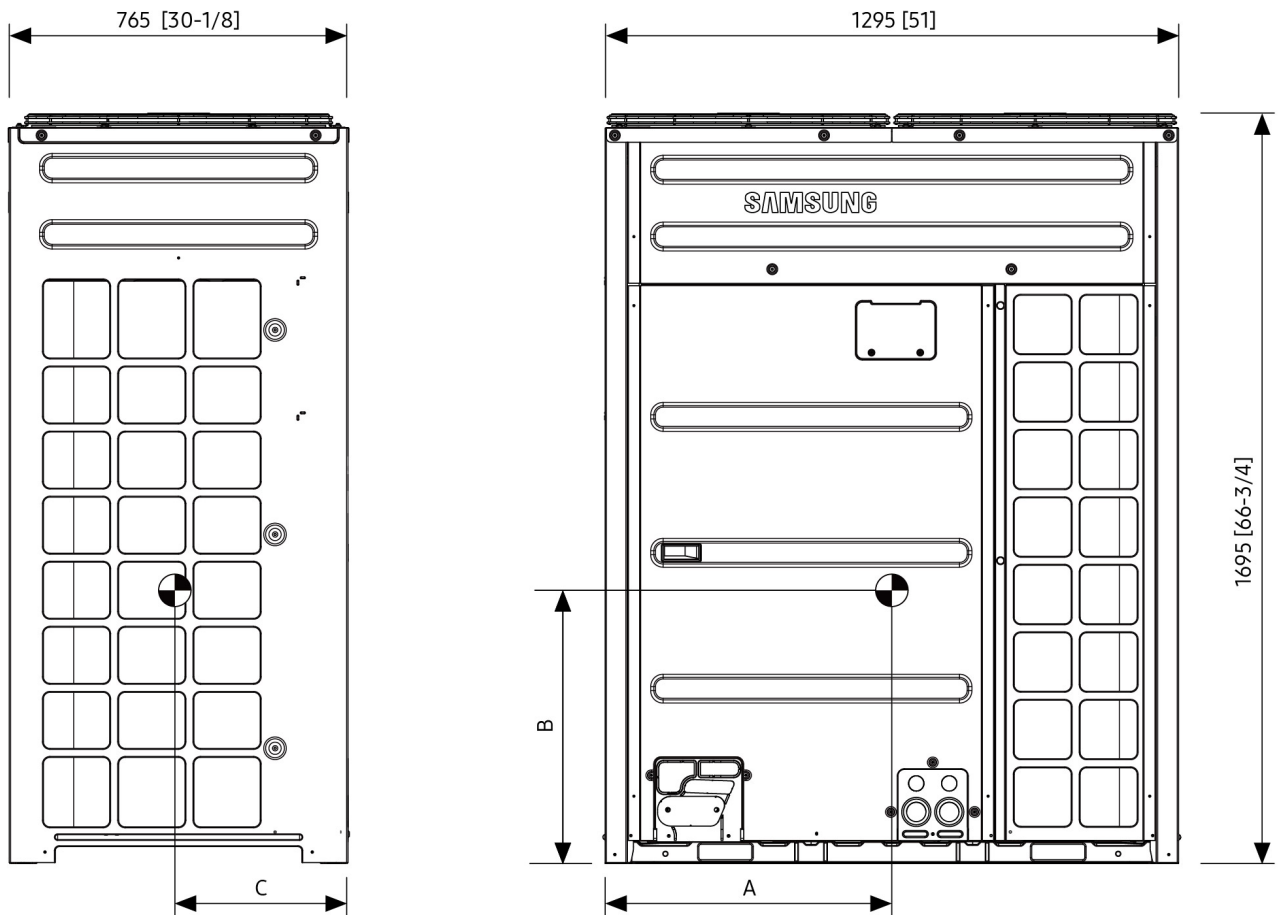

Model	A	B	C
AM160HCVANG/EU AM180HCVANG/EU AM200HCVANG/EU	520 [20-1/2]	678 [26-11/16]	324 [12-3/4]

6. Electrical Wiring Diagram

DVM S2+

AM080HCVANG/EU, AM100HCVANG/EU, AM120HCVANG/EU

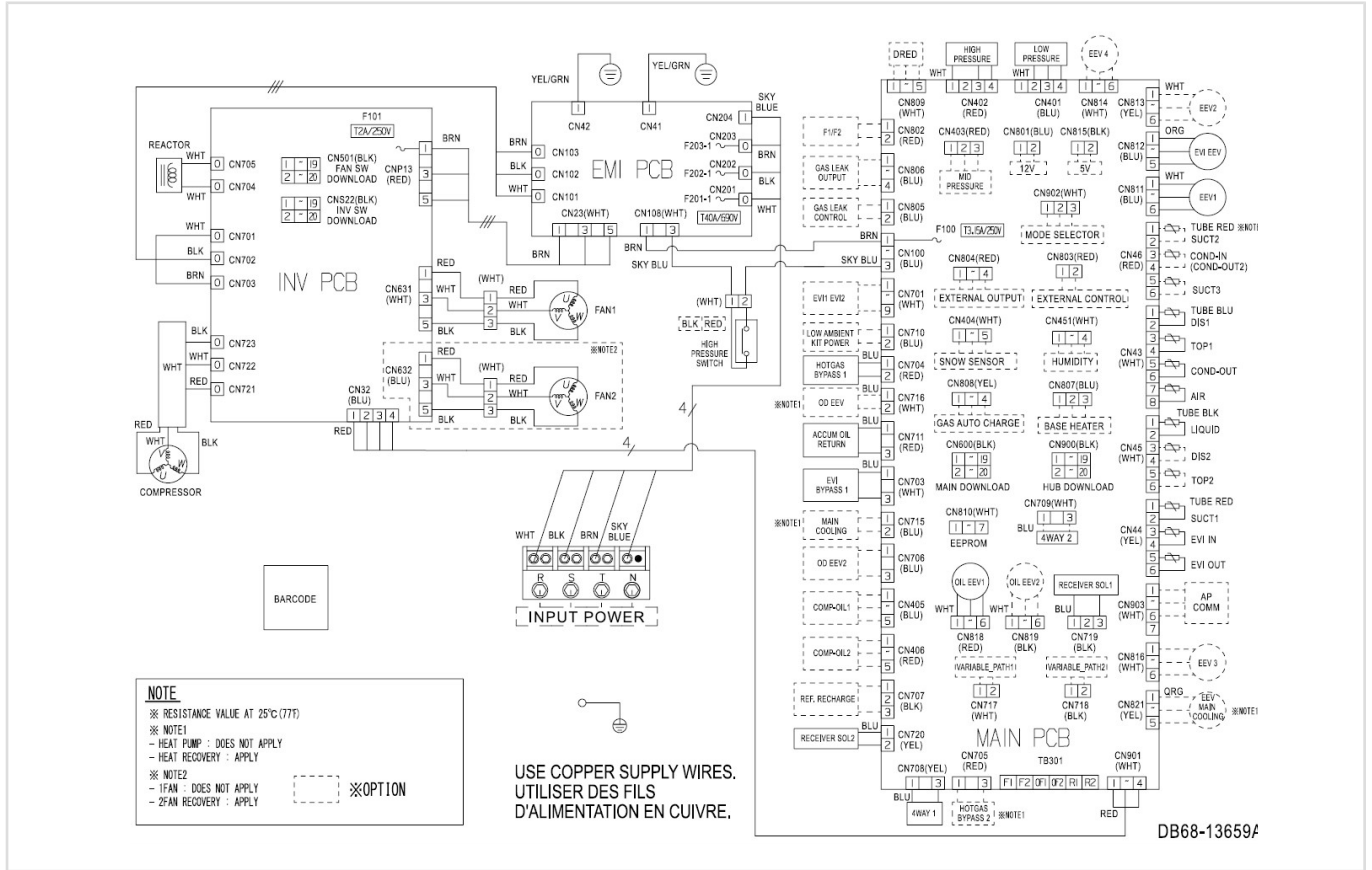

EMI PCB1	Printed circuit board (emi1)	EVI-OUT(10K)	Thermistor (EVI-out_10kohm)	EVI BYPASS1 V/V	Solenoid valve (EVI BYPASS)
MAIN PCB	Printed circuit board (main)	EVI-IN(10K)	Thermistor (EVI-in_10kohm)	ACCUM OIL RETURN V/V	Solenoid valve (Accumulator Oil Return)
AP PCB	Printed circuit board (main)	SUCT1(10K)	Thermistor (Suction Temp.1_10Kohm)	MAIN COOLING	Solenoid valve (Main cooling)
WIFI MODULE	WIFI MODULE	SUCT2(10K)	Thermistor (Suction Temp.2_10Kohm)	HOTGAS2 BYPASS V/V	Solenoid valve (Hot Gas Bypass2)
COMPRESSOR1	Motor (compressor1)	SUCT3(10K)	Thermistor (Suction Temp.2_10Kohm)	OD EEV V/V	Electronic expansion valve (Outdoor EEV)
FAN1	Motor (fan1)	COND IN(10K)	Thermistor (Cond In Temp._10Kohm)	OD EEV2 V/V	Electronic expansion valve (Outdoor EEV)
FAN2	Motor (fan2)	AIR(10K)	Thermistor (Ambient Temp._10Kohm)	F1/F2	FUSE (INV PCB)
EVI V/V1	Solenoid valve (EVI1)	COND(10K)	Thermistor (Cond Out Temp._10Kohm)	MODE SELECTOR	Connector (Remote switching cool/heat selector)
EVI V/V2	Solenoid valve (EVI2)	TOP1(200K)	Thermistor (Compressor Top 1_200Kohm)	EXTERNAL CONTROL	Connector (Output EXTERNAL CONTROL)
EVI EEV	Electronic expansion valve (EVI)	TOP2(200K)	Thermistor (Compressor Top 2_200Kohm)	EXTERNAL OUTPUT	Connector (Output EXTERNAL)
EEV1	Electronic expansion valve 1	DIS1(200K)	Thermistor (Discharge Temp.1_200Kohm)	EXTERNAL OUTPUT	Communication
EEV2	Electronic expansion valve 2	DIS2(200K)	Thermistor (Discharge Temp.2_200Kohm)	F1/F2	Communication
EEV3	Electronic expansion valve 3	LIQUID(10K)	Thermistor (Liquid Tube Temp._10Kohm)	HIGH PRESSURE	PRESSURE SENSOR
EEV4	Electronic expansion valve 4	REACTOR	REACTOR	MID PRESSURE	PRESSURE SENSOR
4WAY1 V/V	Solenoid valve (4 Way valve1)	EEPROM	Printed circuit board(EEPROM PCB)	LOW PRESSURE	PRESSURE SENSOR
4WAY2 V/V	Solenoid valve (4 Way valve2)	VARIABLE PATH1	Solenoid valve(VARIABLE PATH1)	RECEIVER SOL1	Solenoid valve(RECEIVER1)
OIL EEV1	Electronic expansion valve(OIL1)	VARIABLE PATH2	Solenoid valve(VARIABLE PATH2)	RECEIVER SOL2	Solenoid valve(RECEIVER2)
OIL EEV2	Electronic expansion valve(OIL2)	HUMIDITY	SENSOR(HUMIDITY)	BASE HEATER	HEATER
EEV MAIN COOLING	Electronic expansion valve (EEV MAIN COOLING)	HOTGAS1	Solenoid valve (Hot Gas Bypass1)	AP COMM	Communication
SNOW SENSOR	SNOW SENSOR	DRED	Printed circuit board(DRED PCB)		

NOTE

- This wiring diagram applies only to the outdoor unit.
- Colors blk: black, red: red, blu: blue, wht: white, yel: yellow, brn: brown, sky: skyblue
- When operating, don't shortcircuit the protection device (High Pressure switch)
- For connection wiring indoor-outdoor transmission F1-F2, outdoor_outdoor transmission OF1-OF2, refer to the installation manual.
- Protective earth(screw), : connector, : The wire quantity

6. Electrical Wiring Diagram

DVM S2+

AM160HCVANG/EU, AM180HCVANG/EU, AM200HCVANG/EU

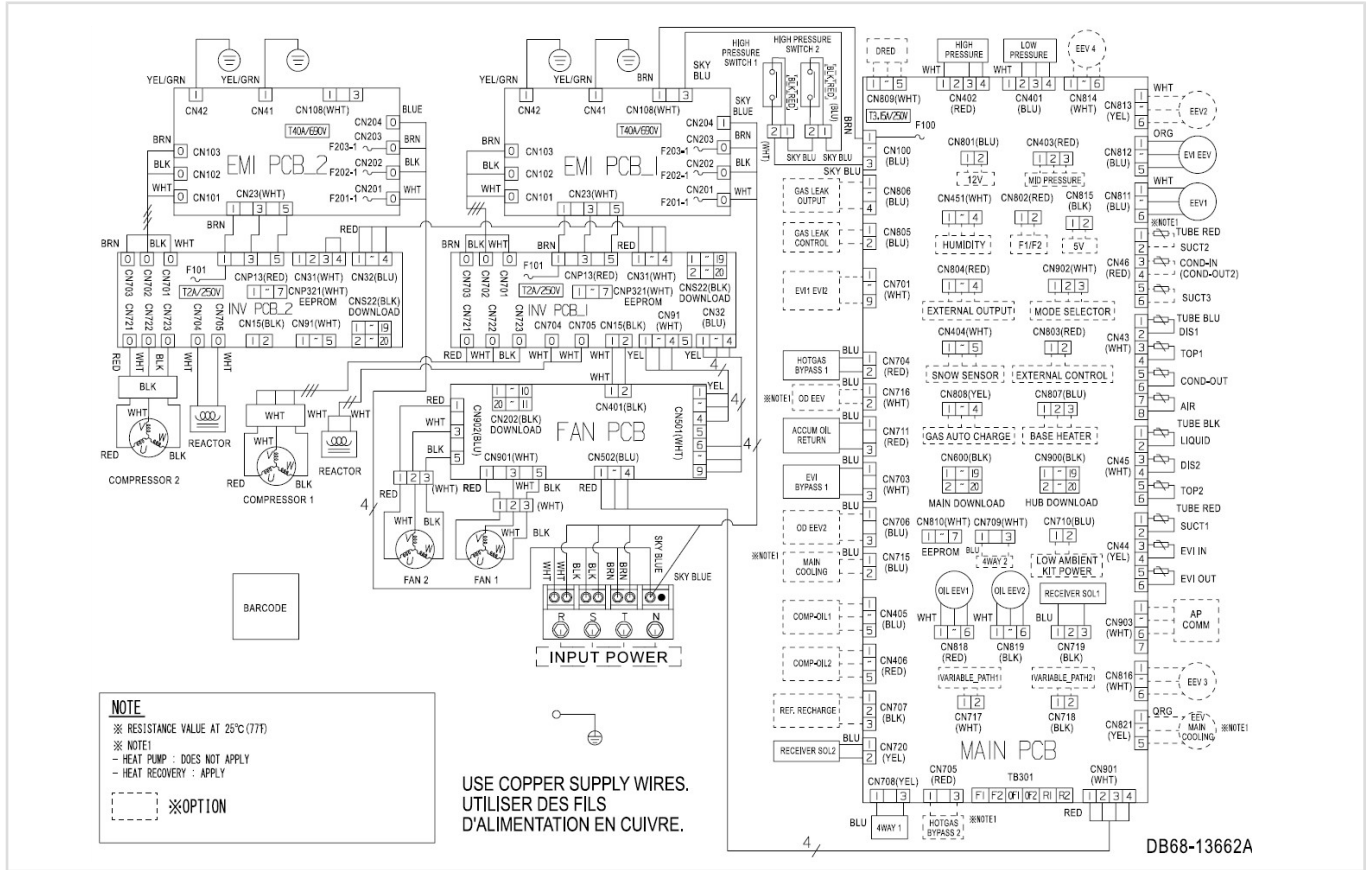

INV PCB2	Printed circuit board (inverter2)	SNOW SENSOR	SNOW SENSOR	OIL EEV2	Electronic expansion valve(OIL2)
EMI PCB1	Printed circuit board (emi1)	EVI-OUT(10K)	Thermistor (EVI-out_10kohm)	HOTGAS1 BYPASS V/V	Solenoid valve (Hot Gas Bypass1)
EMI PCB2	Printed circuit board (emi2)	EVI-IN(10K)	Thermistor (EVI-in_10kohm)	EVI BYPASS1 V/V	Solenoid valve (EVI BYPASS)
FAN PCB	Printed circuit board (fan)	SUCT1(10K)	Thermistor (Suction Temp.1_10Kohm)	ACCUM OIL RETURN V/V	Solenoid valve (Accumulator Oil Return)
MAIN PCB	Printed circuit board (main)	SUCT2(10K)	Thermistor (Suction Temp.2_10Kohm)	MAIN COOLING	Solenoid valve (Main cooling)
AP PCB	Printed circuit board (main)	SUCT3(10K)	Thermistor (Suction Temp.2_10Kohm)	HOTGAS2 BYPASS V/V	Solenoid valve (Hot Gas Bypass2)
WIFI	WIFI MODULE	COND IN(10K)	Thermistor (Cond In Temp_10Kohm)	OD EEV V/V	Electronic expansion valve (Outdoor EEV)
COMPRESSOR1	Motor (compressor1)	AIR(10K)	Thermistor (Ambient Temp_10Kohm)	OD EEV2 V/V	Electronic expansion valve (Outdoor EEV)
COMPRESSOR2	Motor (compressor2)	COND(10K)	Thermistor (Cond Out Temp_10Kohm)	F101	FUSE (INV PCB)
FAN1	Motor (fan1)	TOP1(200K)	Thermistor (Compressor Top 1_200Kohm)	690V/40A	FUSE (EMI PCB)
FAN2	Motor (fan2)	TOP2(200K)	Thermistor (Compressor Top 2_200Kohm)	MODE SELECTOR	Connector (Remote switching cool/heat selector)
EVI V/V1	Solenoid valve (EVI1)	DIST1(200K)	Thermistor (Discharge Temp.1_200Kohm)	EXTERNAL CONTROL	Connector (Output EXTERNAL CONTROL)
EVI V/V2	Solenoid valve (EVI2)	DIST2(200K)	Thermistor (Discharge Temp.2_200Kohm)	EXTERNAL OUTPUT	Connector (Output EXTERNAL)
EVI EEV	Electronic expansion valve (EVI)	LIQUID(10K)	Thermistor (Liquid Tube Temp_10Kohm)	F1/F2	Communication
EEV1	Electronic expansion valve 1	REACTOR	REACTOR	HIGH PRESSURE	PRESSURE SENSOR(HIGH)
EEV2	Electronic expansion valve 2	EEPROM	Printed circuit board(EEPROM PCB)	MID PRESSURE	PRESSURE SENSOR(MID)
EEV3	Electronic expansion valve 3	VARIABLE PATH1	Solenoid valve(VARIABLE PATH1)	LOW PRESSURE	PRESSURE SENSOR(LOW)
EEV4	Electronic expansion valve 4	VARIABLE PATH2	Solenoid valve(VARIABLE PATH2)	RECEIVER SOL1	Solenoid valve(RECEIVER1)
4WAY1 V/V	Solenoid valve (4 Way valve1)	HUMIDITY	SENSOR(HUMIDITY)	RECEIVER SOL2	Solenoid valve(RECEIVER2)
4WAY2 V/V	Solenoid valve (4 Way valve2)	DRED	Printed circuit board(DRED PCB)	BASE HEATER	HEATER
EEV MAIN COOLING	Electronic expansion valve (EEV MAIN COOLING)	OIL EEV1	Electronic expansion valve(OIL1)	AP COMM	Communication

NOTE

- This wiring diagram applies only to the outdoor unit.
- Colors blk: black, red: red, blu: blue, wht: white, yel: yellow, brn: brown, sky: skyblue
- When operating, don't shortcircuit the protection device (High Pressure switch)
- For connection wiring indoor-outdoor transmission F1-F2, outdoor_outdoor transmission OF1-OF2, refer to the installation manual.
- Protective earth(screw), : connector, : The wire quantity

7. Sound Data

DVM S2+

Sound Pressure Level

Unit : dB(A)

Model	Cooling			Heating
	Silent1	Silent2	Silent3	
AM080HCVANG/EU	53.0	52.0	49.0	58.0
AM100HCVANG/EU	56.0	54.0	49.0	60.0
AM120HCVANG/EU	61.0	59.0	49.0	63.0

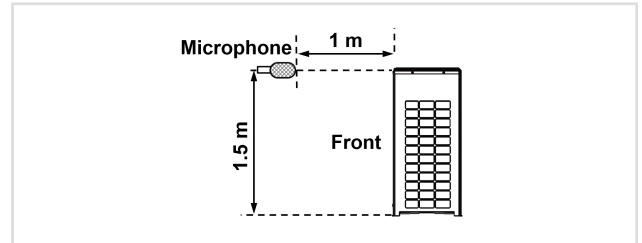

• NR CURVE

(1) AM080HCVANG/EU

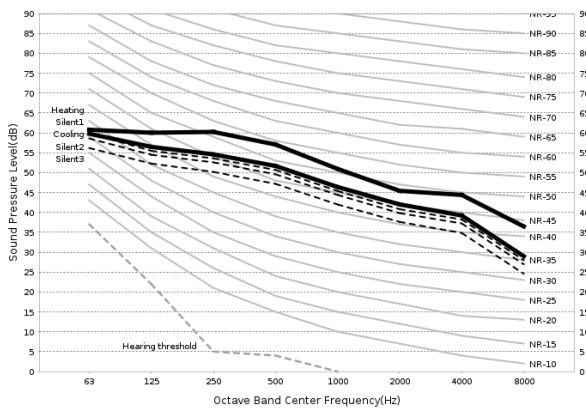

(2) AM100HCVANG/EU

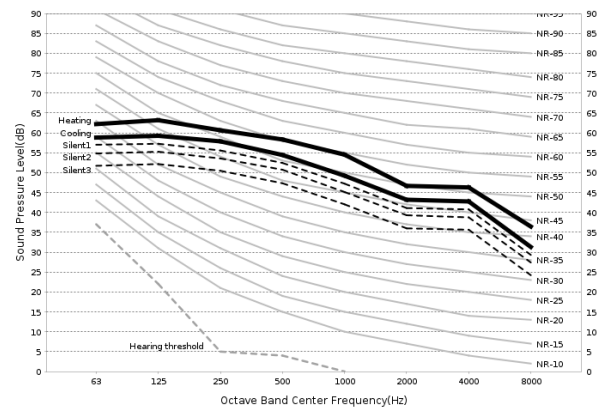

(3) AM120HCVANG/EU

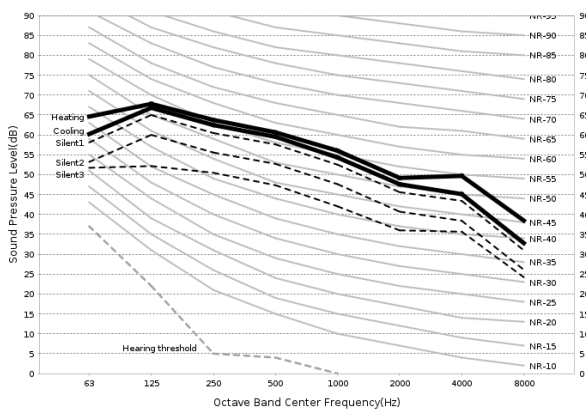

NOTE

- Specifications may be subject to change without prior notice.
- Sound pressure level is obtained in an anechoic room.
- Sound pressure level is a relative value, depending on the distance and acoustic environment.
- Sound pressure level may differ depending on operation condition.
- dBA = A - weighted sound pressure level
- Reference acoustic pressure 0 dB = 20μPa

7. Sound Data

DVM S2+

Sound Pressure Level

Unit : dB(A)

Model	Cooling			Heating
	Silent1	Silent2	Silent3	
AM140HCVANG/EU	63.0	59.0	54.0	65.0
AM160HCVANG/EU	60.0	57.0	55.0	62.0
AM180HCVANG/EU	61.0	57.0	55.0	64.0
AM200HCVANG/EU	61.0	57.0	55.0	63.0

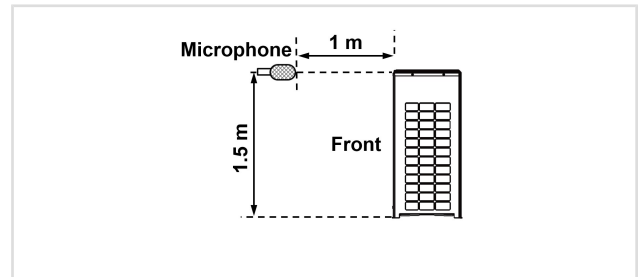

• NR CURVE

(1) AM140HCVANG/EU

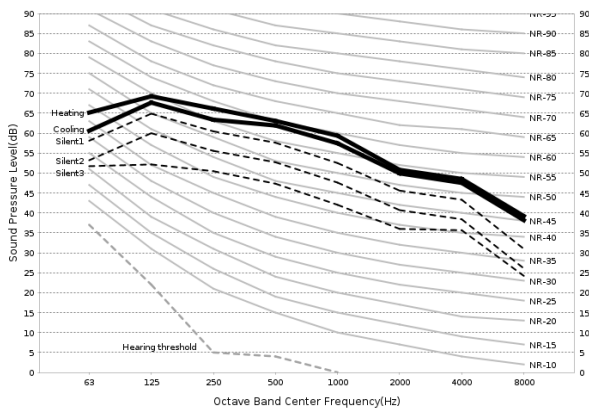

(2) AM160HCVANG/EU

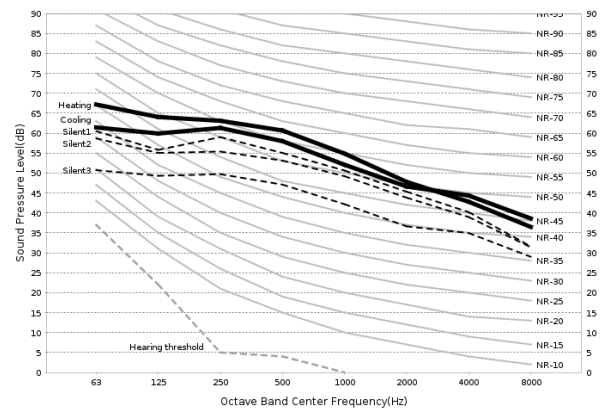

(3) AM180HCVANG/EU

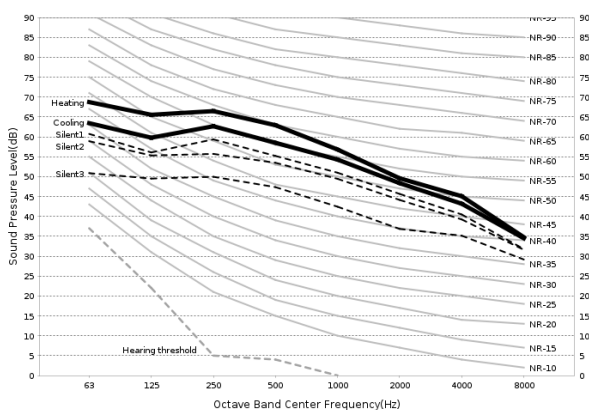

(4) AM200HCVANG/EU

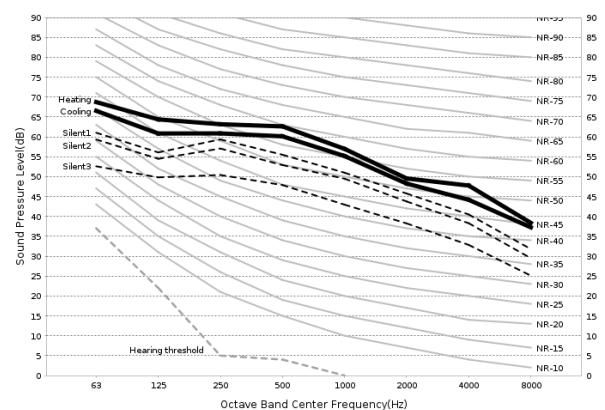

NOTE

- Specifications may be subject to change without prior notice.
- Sound pressure level is obtained in an anechoic room.
- Sound pressure level is a relative value, depending on the distance and acoustic environment.
- Sound pressure level may differ depending on operation condition.
- dBA = A - weighted sound pressure level
- Reference acoustic pressure 0 dB = 20μPa

7. Sound Data

DVM S2+

Sound Power Level

Unit : dB(A)

Model	Cooling	Heating
AM080HCVANG/EU	75.0	80.0
AM100HCVANG/EU	78.0	81.0
AM120HCVANG/EU	81.0	84.0

• NR CURVE

(1) AM080HCVANG/EU

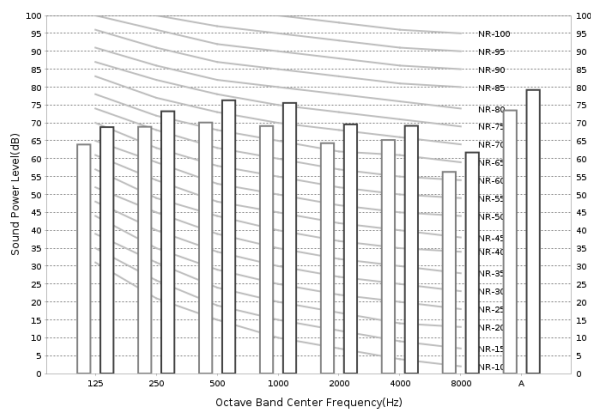

(2) AM100HCVANG/EU

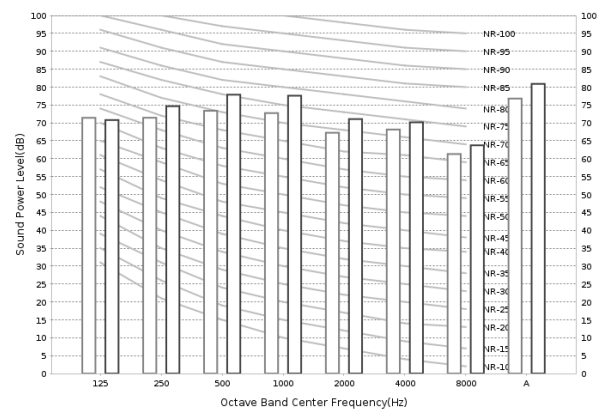

(3) AM120HCVANG/EU

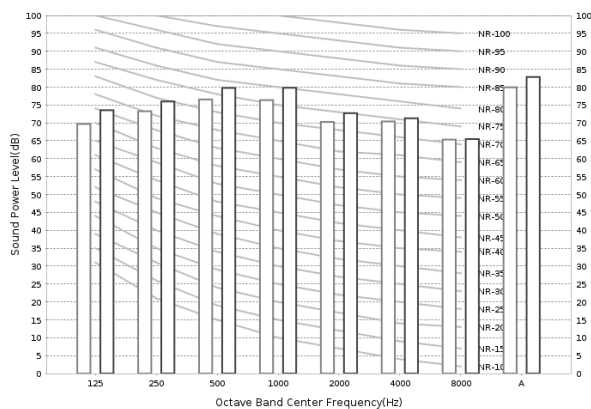

NOTE

- Specifications may be subject to change without prior notice.
- Sound pressure level is obtained in an anechoic room.
- Sound pressure level is a relative value, depending on the distance and acoustic environment.
- Sound pressure level may differ depending on operation condition.
- dBA = A - weighted sound pressure level
- Reference acoustic pressure 0 dB = 20μPa

7. Sound Data

DVM S2+

Sound Power Level

Unit : dB(A)

Model	Cooling	Heating
AM140HCVANG/EU	85.0	86.0
AM160HCVANG/EU	81.0	83.0
AM180HCVANG/EU	83.0	86.0
AM200HCVANG/EU	84.0	85.0

• NR CURVE

(1) AM140HCVANG/EU

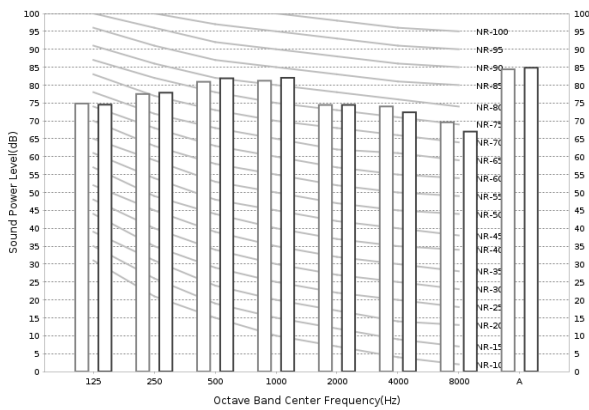

(2) AM160HCVANG/EU

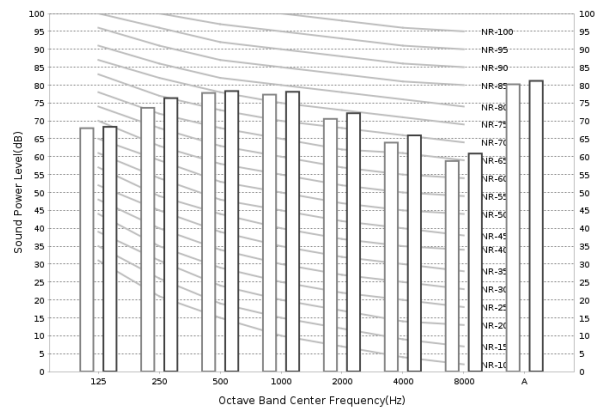

(3) AM180HCVANG/EU

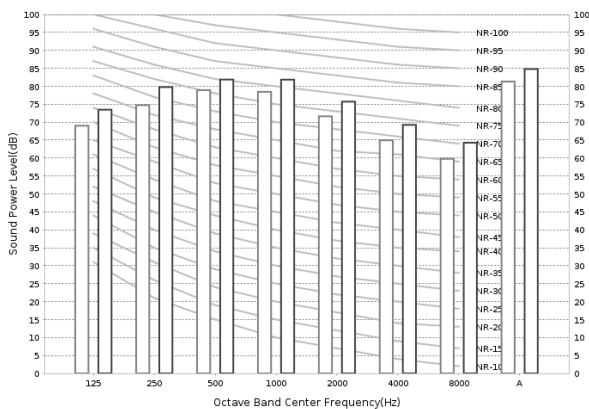

(4) AM200HCVANG/EU

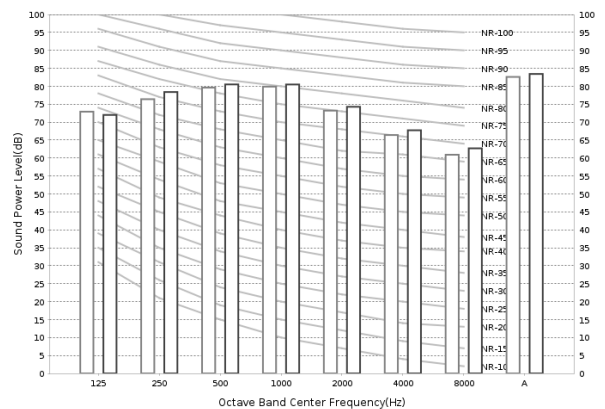

NOTE

- Specifications may be subject to change without prior notice.
- Sound pressure level is obtained in an anechoic room.
- Sound pressure level is a relative value, depending on the distance and acoustic environment.
- Sound pressure level may differ depending on operation condition.
- dBA = A - weighted sound pressure level
- Reference acoustic pressure 0 dB = 20μPa

8. Operation Range

DVM S2+

• Cooling

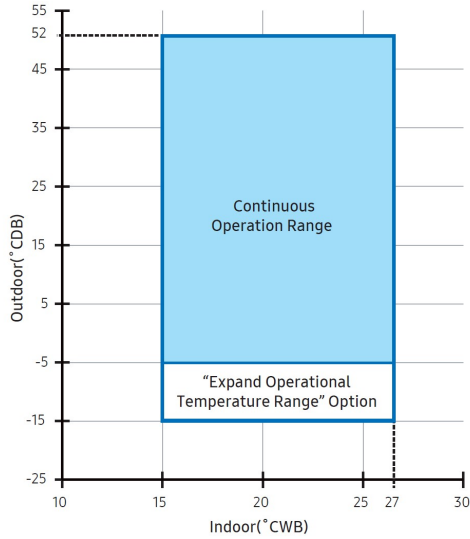

• Heating

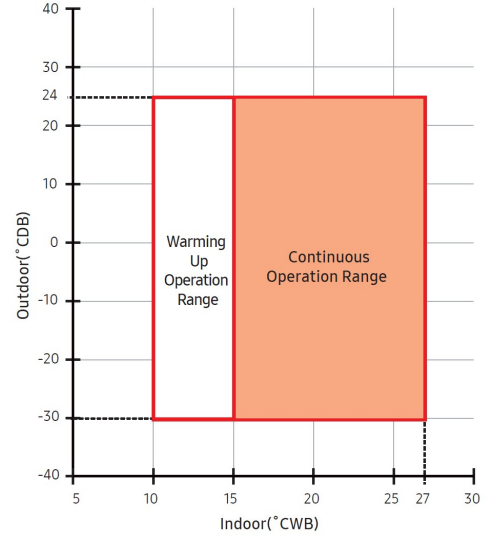

NOTE

- (1) The operating range is shown in these figures
- (2) The assumed installation conditions are as follows
 - Outdoor units and indoor units combination
 - The Pipe length(including elbow) is 5m (16.4ft)
 - The Level difference is 0m
- (3) In the low temperature expansion option application, the cooling operating is possible under expand operational range only for HR system
- (4) In case of heating mode, operating is possible under warming up operation range. However continuous operating is impossible due to a protection control

8. Operation Range

DVM S2+

Defrosting correction factor

The heating capacity tables do not take account of the reduction in capacity, when frost has accumulated or while the defrosting operation is in progress.

The capacity values, which take these factors into account, in other words, the integrated heating capacity values, can be calculated as follows :

Formula : $A = B \times C$

Integrated heating capacity = A

Value given in table of capacity characteristics = B

Integrating correction factor for frost accumulation (kW) = C

Outdoor temperature (°C, DB/WB)	-10/-10.4	-8/-8.5	-6/-6.5	-4/-4.6	-2/-2.7	0/-0.7	2/1.2	5/4.1	7/6
Capacity coefficient	0.99	0.98	0.96	0.95	0.91	0.88	0.86	0.91	1.00

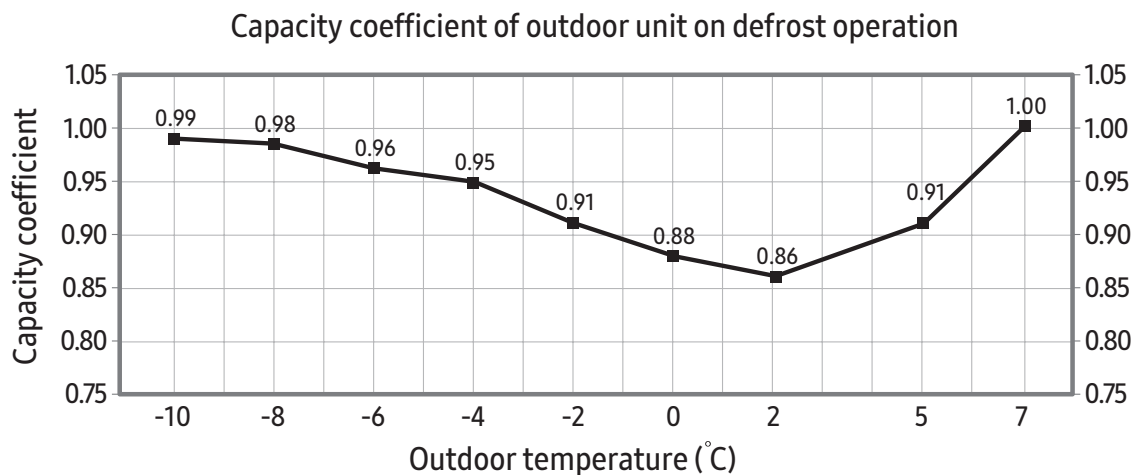

On heating operation, frost can be formed on heat exchanger according to outdoor temperature. (Frost on heat exchanger results in decreasing the performance.)

To remove frost on heat exchanger of outdoor unit, defrost operation is carried out periodically.

During defrost operation, capacity of outdoor unit may decrease.

The decrement is not considered to the individual capacity tables.

This figure shows an effect of intelligence defrost operation

It is actually the frost occurrence section from 0 °C or less.

Since the outdoor temperature over 0 °C, the heating performance is the same before and after applying intelligence defrost operation

In outdoor conditions below 0 °C, frost conditions reflect the actual entering the defrost operation because heating performance is improved

9. Piping Diagram

DVM S2+

AM080HCVANG/EU, AM100HCVANG/EU, AM120HCVANG/EU, AM140HCVANG/EU

- Cooling

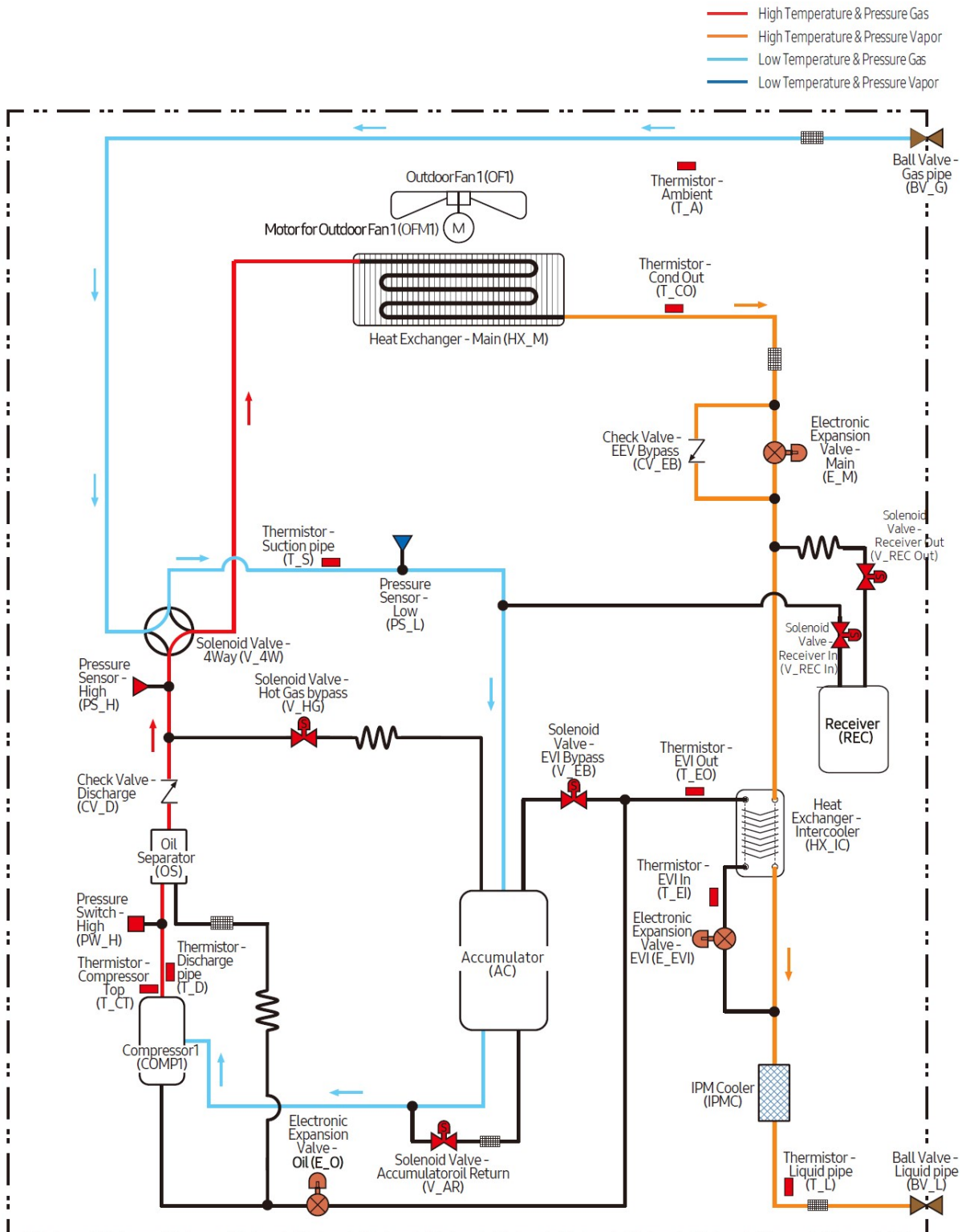

9. Piping Diagram

DVM S2+

AM080HCVANG/EU, AM100HCVANG/EU, AM120HCVANG/EU, AM140HCVANG/EU

- Heating

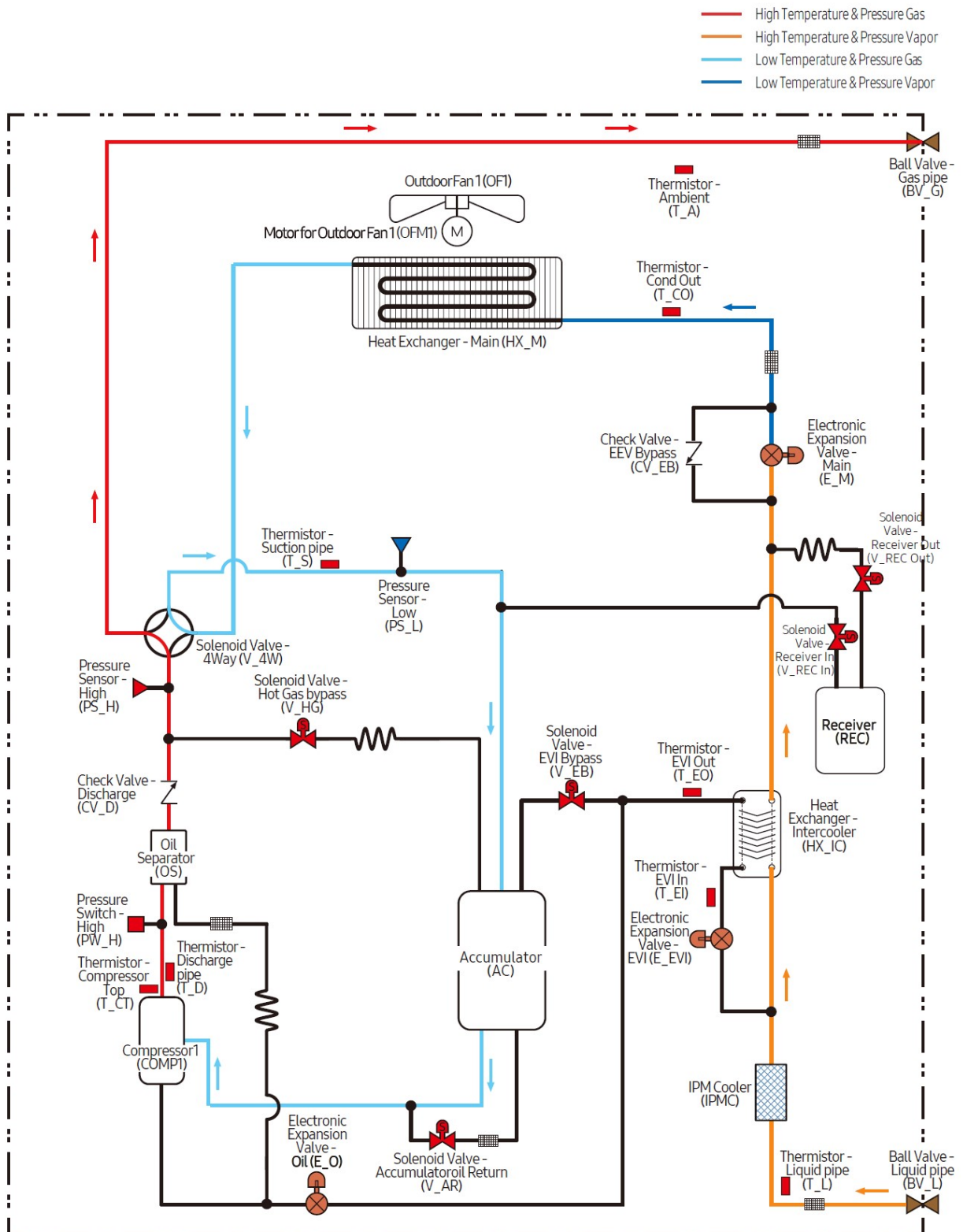

9. Piping Diagram

DVM S2+

AM160HCVANG/EU, AM180HCVANG/EU, AM200HCVANG/EU

• Cooling

- High Temperature & Pressure Gas
- High Temperature & Pressure Vapor
- Low Temperature & Pressure Gas
- Low Temperature & Pressure Vapor

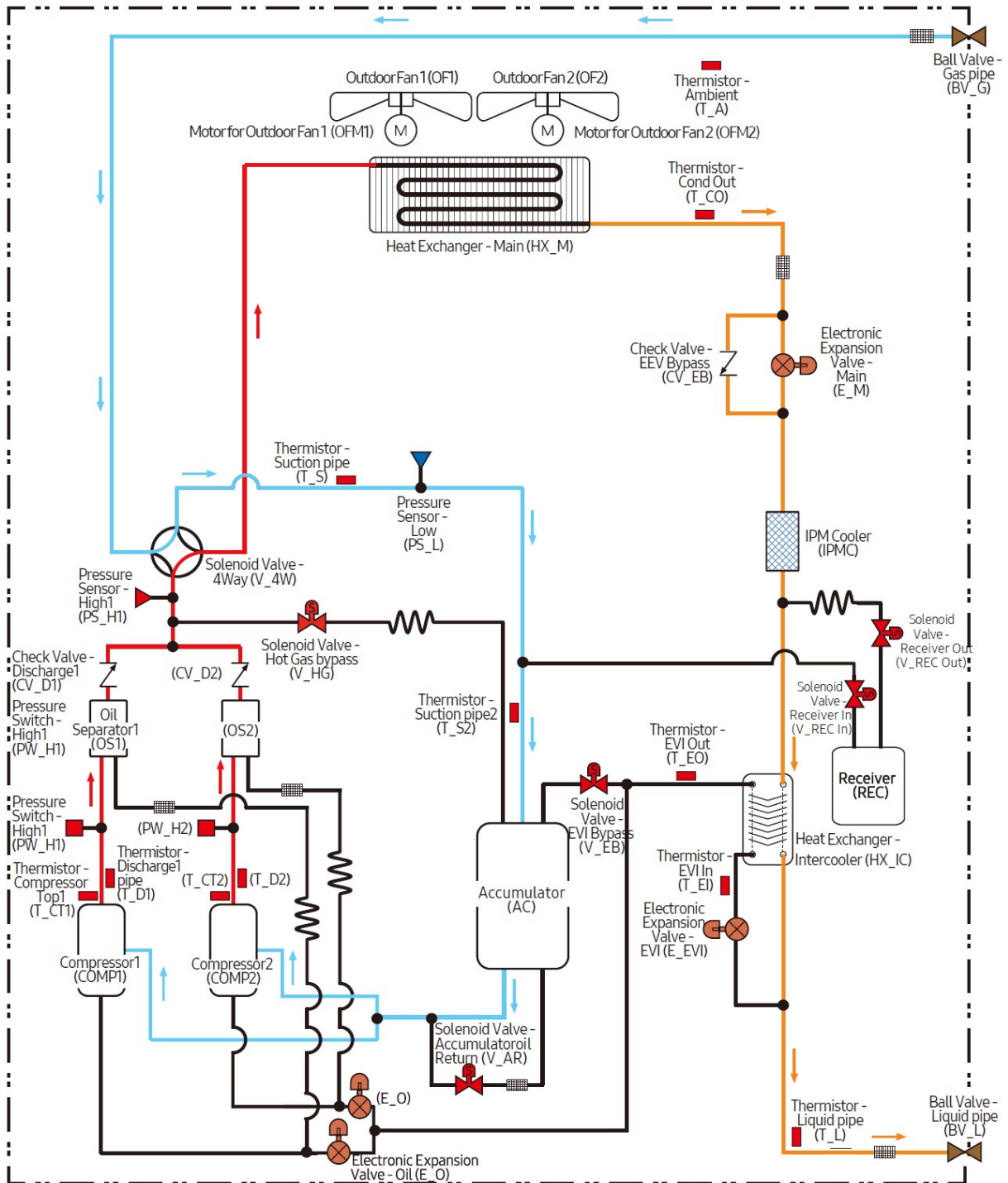

9. Piping Diagram

DVM S2+

AM160HCVANG/EU, AM180HCVANG/EU, AM200HCVANG/EU

• Heating

- High Temperature & Pressure Gas
- High Temperature & Pressure Vapor
- Low Temperature & Pressure Gas
- Low Temperature & Pressure Vapor

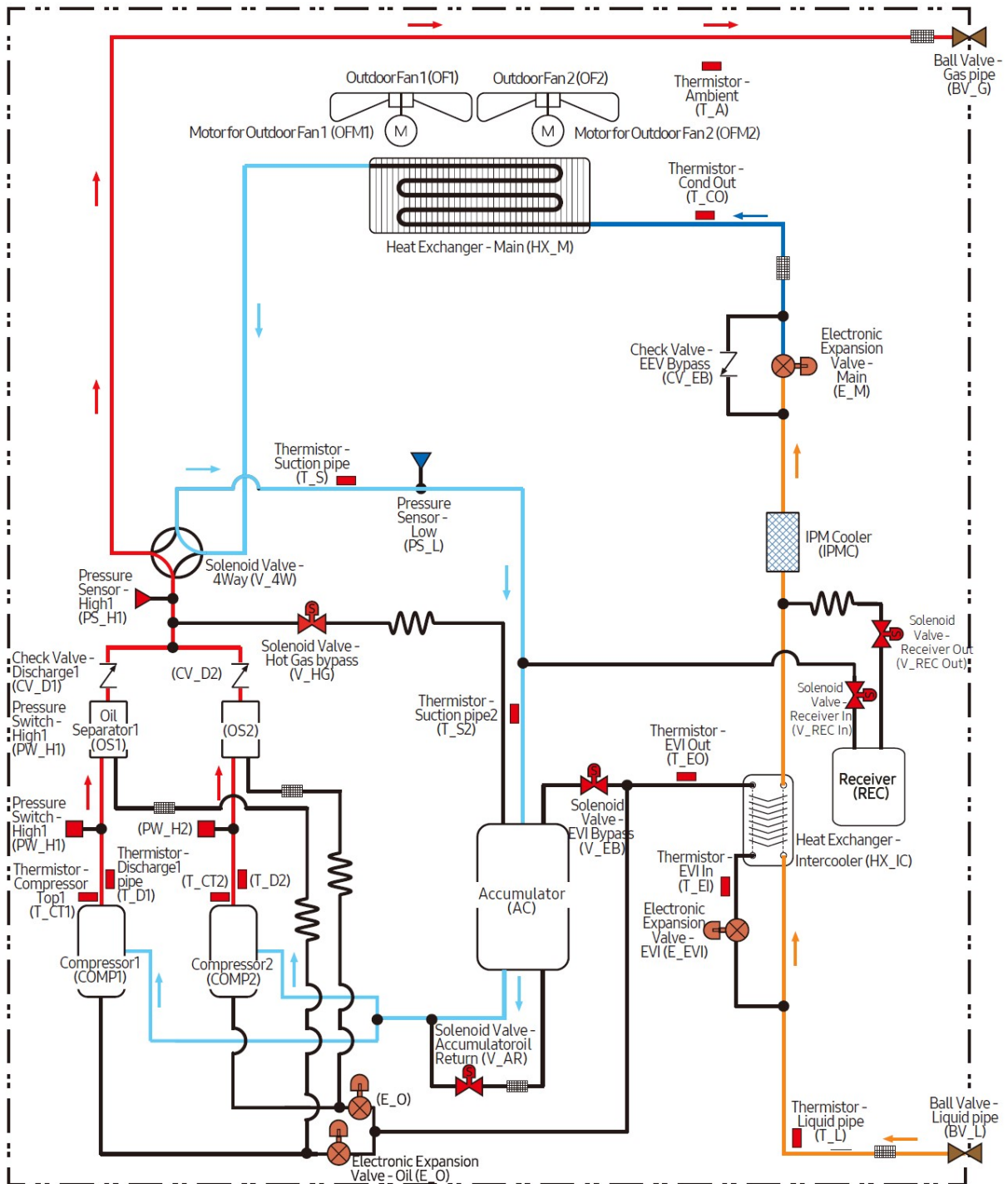

※ Installation

Choosing the installation location

Outdoor unit location requirements

Decide the installation location, with the consideration of the following conditions, under user's approval.

- Place where hot discharge air or noise from the outdoor unit may not disturb the neighbor (Especially in residential areas, keep the operation hours in mind.)
- Place where structure can bear the weight and vibration of the outdoor unit.
- Place with flat surface where rainwater does not settle or leak.
- Place where it is not exposed to strong wind.
- Well ventilated place with sufficient service place for repairs and maintenance. (Discharge duct must be purchased separately in your local market.)
- Place where you can connect the refrigerant pipes between indoor and outdoor units within allowable distance.
- Place where it allows easy waterproofing and draining work for the condensation water generated from the outdoor unit during heating operation.
- Place where there is no risk of inflammable gas leakage.
- Place where there is no direct influence of snow or rain.
- Place where a large amount of water generated by external environment does not directly affect the top of the outdoor unit

Installation Guide at the seashore

Make sure to follow below guides when installing at the seashore.

- 1 Do not install the product in a place where it is directly exposed to sea water and sea breeze.
 - Make sure to install the product behind a structure (such as building) that can block sea breeze.
 - Even when it is inevitable to install the product in seashore, make sure that product is not directly exposed to sea breeze by installing a protection wall.

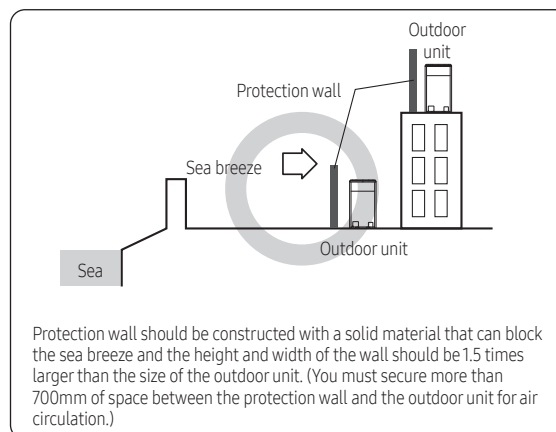

- 2 Consider that the salinity particles clinging to the external panels should be sufficiently washed out.
- 3 Because the residual water at the bottom of the outdoor unit significantly promotes corrosion, make sure that the slope does not disturb drainage.
 - Keep the floor level so that rain does not accumulate.
 - Be careful not to block the drain hole due to foreign substance
- 4 When product is installed in seashore, periodically clean it with water to remove attached salinity.
- 5 Make sure to install the product in a place that provides smooth water drainage. Especially, ensure that the base part has good drainage.
- 6 If the product is damaged during the installation or maintenance, make sure to repair it

※ Installation

Choosing the installation location

- 7 Check the condition of the product periodically.
 - Check the installation site every 3 months and perform anti-corrosion treatment such as R-Pro supplied by SAMSUNG (Code : MOK-220SA) or commercial water repellent grease and wax, etc., based on the product condition.
 - When the product is to be shut down for a long period of time, such as off-peak hours, take appropriate measures like covering the product.
 - 8 If the product installed within 500m (1640 ft) of seashore, special anti-corrosion treatment is required.
 - ※ Please contact your local SAMSUNG representative for further details.
- If you cannot find a proper location to install the outdoor unit, consult with an expert or specialty store.

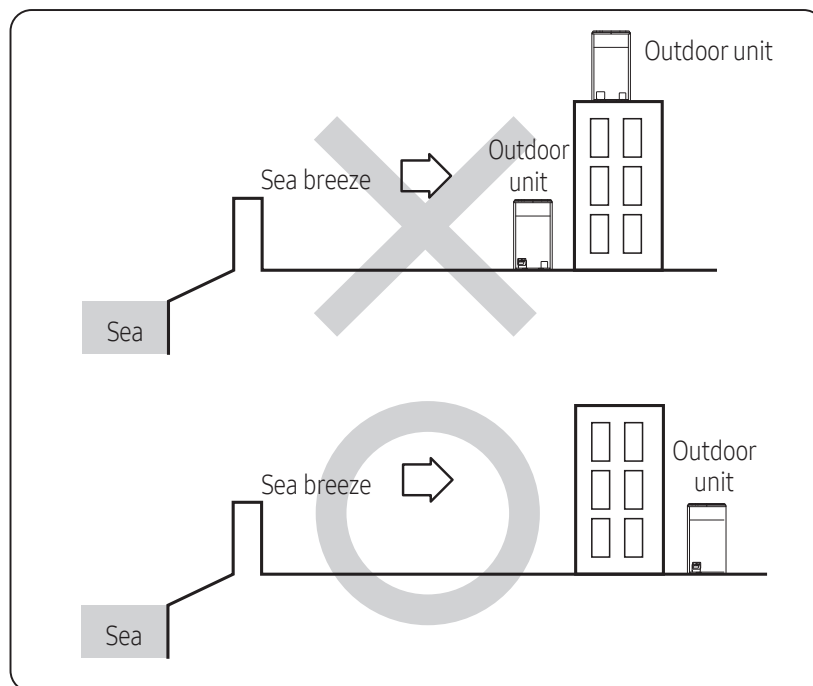

⚠ CAUTION

- System air conditioner may cause static noise when listening to AM stations. Therefore, select an installation location for indoor unit where electrical wiring can be done while keeping certain distance from a radio, computer and stereo equipment.
 - Especially, keep the unit at least 3m away from the electrical equipment in an area with weak electromagnetic waves and put the main power cable and communication cables in a separately installed protection tube.
 - Make sure that there is no equipment that generates electromagnetic waves. If not electromagnetic waves may cause problem to the control systems which may lead to air conditioner malfunction. (Example: Remote control sensor of the indoor unit may not receive the signal very well, due to ballast stabilizer of the lighting equipment.)
- In regions with heavy snowfall, make sure to install the outdoor unit where there is no concerns of direct snowfall on the outdoor unit. Also, build higher base support so that accumulated snow does not block the air inlet or the heat exchanger.
- R-32 refrigerant is slightly flammable. Therefore, a ventilation device is required if the outdoor unit is installed indoors or in an enclosed area.
- When you install the outdoor unit in high places such as a roof, install fence or guardrail around it. When there is no fence or guardrail, service person could fall.
- Do not install the product in places where corrosive gases such as sulfur oxides, ammonia, and sulfurous gas are produced. (e.g. Toilet outlet, ventilation opening, sewage works, dyeing complex, cattle shed, sulfuric hot spring, nuclear power plant, ship etc.) When installing the product in those places, contact an installation specialty store as the copper pipe and brazing part will need additional corrosion proof or anti-rust additive to prevent corrosion.
- Make sure not to keep any inflammable materials (such as wooden materials, oil etc.) around the outdoor unit. When there's fire, those inflammable material will easily catch the fire and may pass it on to the product.

※ Installation

Choosing the installation location

- Depending on the condition of power supply, unstable power or voltage any cause malfunction of the parts or control system. (At the ship or places using power supply from electric generator...etc)
- Make sure to install MCU when using HR products.
- Make sure to install SVB when using HP products.

※ SVB(Shut-off Valve Box): An auxiliary device installed to reduce the indoor refrigerant leakage when installing a H/P model for R-32 refrigerant

- When you select the location to install the MCU, the location is far away from indoor rooms because the refrigerant running of MCU may create noise.

Outdoor unit space requirements

- Space requirement was decided based on following conditions; Cooling mode, outdoor temperature of 35 °C. Larger space is required if the outdoor temperature is higher than 35 °C or if the place is heated easily by quantity of solar radiation.
- When you secure installation space, consider path for people and the direction of the wind.
- Secure installation space as shown in the below illustration, considering ventilation and the service space.
- If the installation space is narrow, installer or other worker may get injured during work and may also cause problem to the product.
- If you install multiple number of outdoor units in one space, make sure to secure enough ventilation space if there's any walls around the product that may disturb the air flow. If enough ventilation space is not secured, product may malfunction.
- You may install the outdoor units with 20mm of space between the product, but product's performance may decrease depending on the installation environment.

Single installation

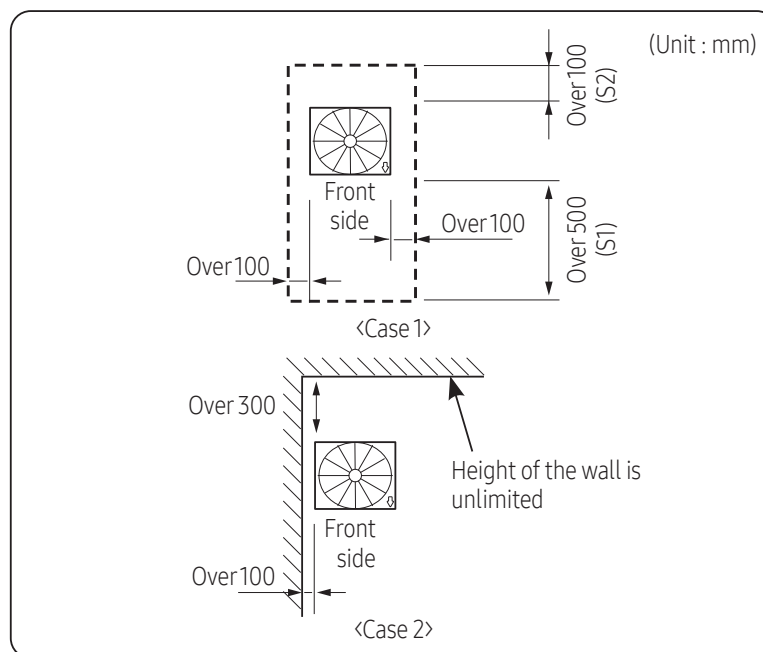

※ Installation

Choosing the installation location

Module installation

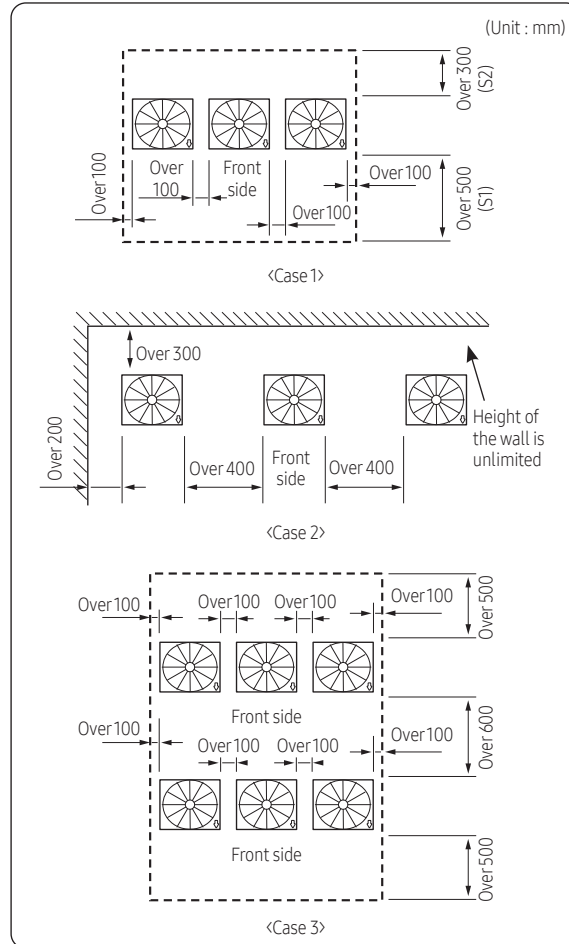

- For <Case 1> or <Case 3>
 - Height of the wall on the front side should not be higher than 1500mm.
 - Height of the wall on the air inlet side should not be higher than 500mm.
 - Height of the wall on the side is not limited.
 - If the height of the wall exceeds by certain value (h_1 , h_2), additional clearance [$(h_1)/2$, $(h_2)/2$: Half of the exceeded height] should be added to the service space (S_1 , S_2).

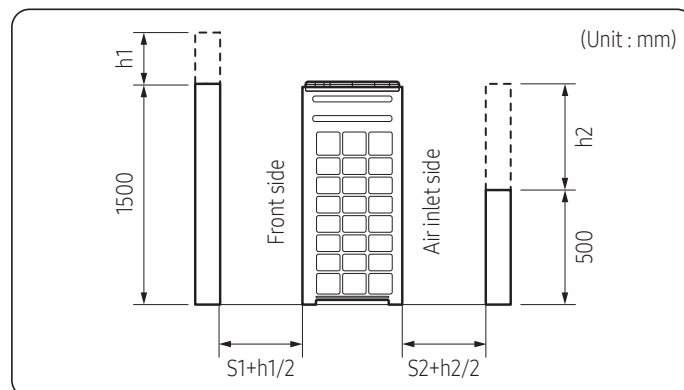

※ Installation

Preparing materials and tools

- You must keep the installation manual until the installation is finished.
- Hand over the installation manual to the customer after finishing the installation.

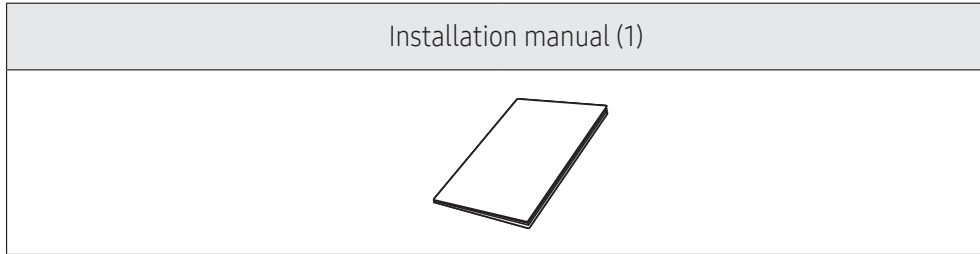

※ Certain models are supplied with a packing socket. The socket type may differ, depending on the model.

Optional accessories

- Following optional accessories are needed for connecting pipes between the indoor and outdoor units.

Classification	Model Name
Y-Joint	MXJ-YA1509M
	MXJ-YA2512M
	MXJ-YA2812M
	MXJ-YA2815M
	MXJ-YA3419M
	MXJ-YA4119M
	MXJ-YA4422M

Classification	Model Name
Y-Joint (Only H/R)	MXJ-YA1500M
	MXJ-YA2500M
	MXJ-YA3100M
	MXJ-YA3800M
Distribution header	MXJ-HA2512M
	MXJ-HA3115M
	MXJ-HA3819M
Y-Joint - Outdoor unit	MXJ-TA3419M
	MXJ-TA4122M
Y-Joint (Only H/R) - Outdoor unit	MXJ-TA3100M
	MXJ-TA3800M

- ※ If you use an indoor unit with no internal EEV(Electric Expansion Valve), you will need an EEV kit.
- ※ Only use the genuine accessories listed in above table and do not use imitated accessories.
- ※ Please refer to the “Refrigerant Pipe Installation” section on the back page for the criteria for accessory selection.

※ Installation

Outdoor unit installation

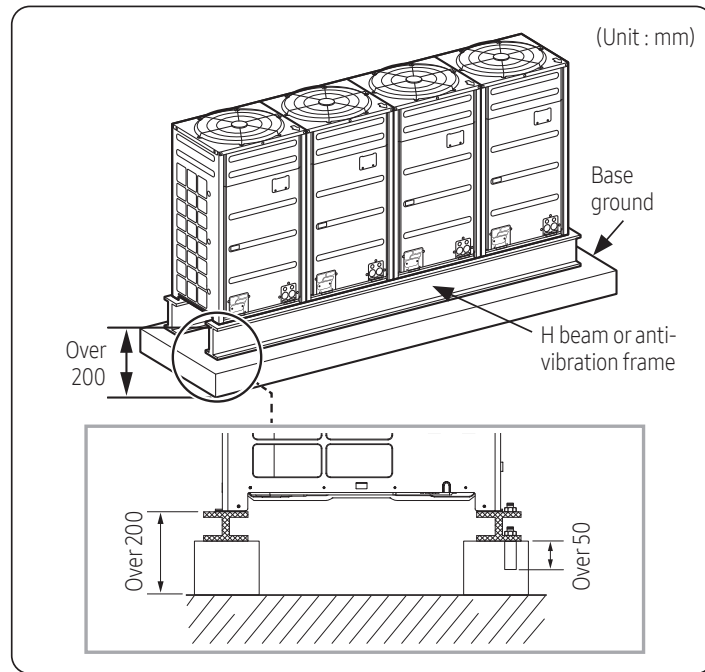

Outdoor unit base mount and anchor bolt position

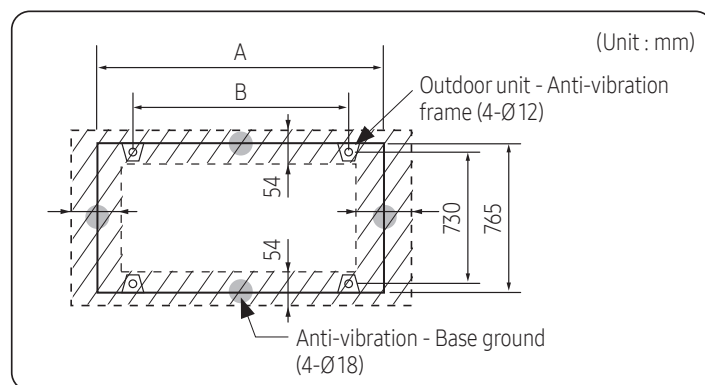

(Unit : mm)

Classification (mm)	DVM S2 Small Type	DVM S2 Large Type
		W930 x H1695 x D765
A	930	1295
B	790	1155

※ Refer to the blueprints in technical data book to make a holes for connecting the anti-vibration pad.

※ Installation

Outdoor unit installation

Examples of draining work

- Construct the drainage ditch with reinforced concretes and make sure that water-proofing work is done.
- For smooth draining of defrost water, make sure to apply 1/50 slope.
- Construct a drainage around the outdoor unit to prevent the defrost water (from the outdoor unit) from stagnating, overflowing or freezing near the installation space.
- When the outdoor unit is installed on the roof, check the strength and waterproof status of the roof.

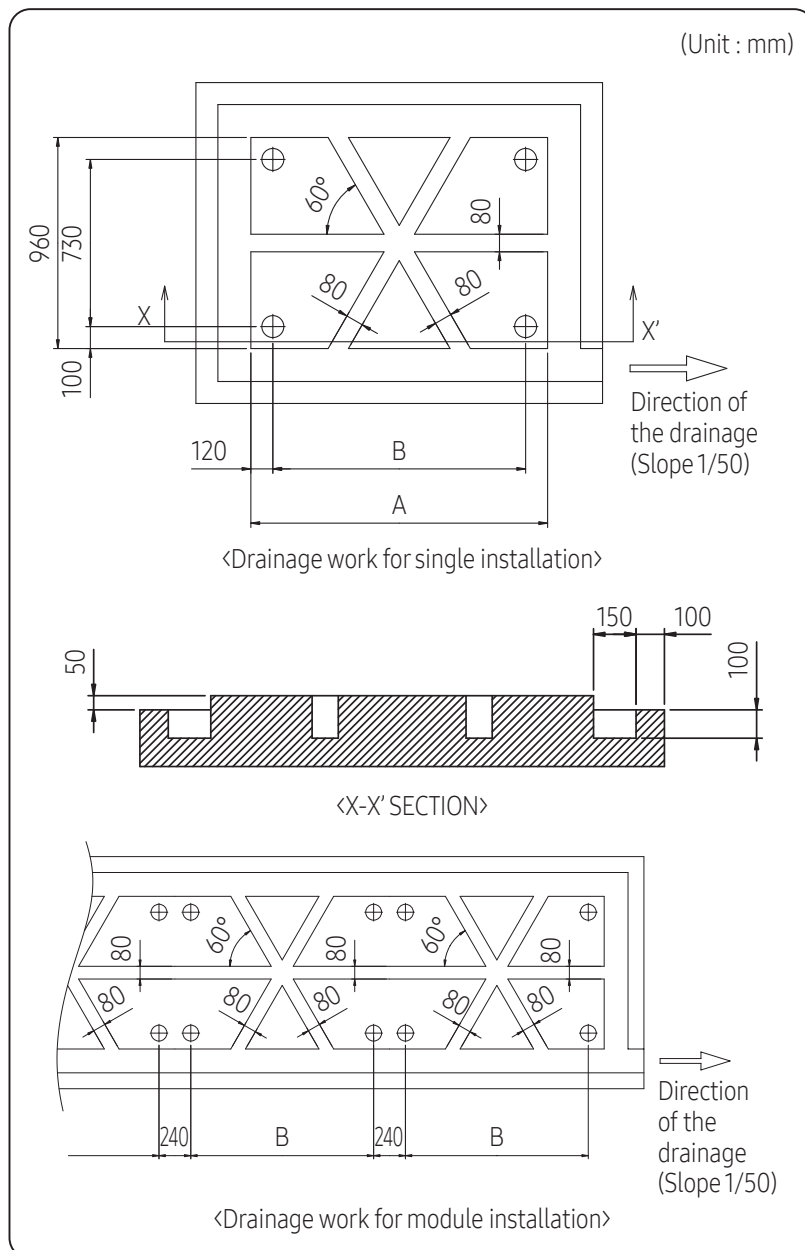

(Unit : mm)

Classification	DVM S2 Small Type	DVM S2 Large Type
A	1030	1395
B	790	1155

※ Installation

⚠ CAUTION

- Cautions regarding on connecting the anchor bolt
 - Tighten the rubber washer to prevent the bolt connection part of the outdoor unit from corroding.

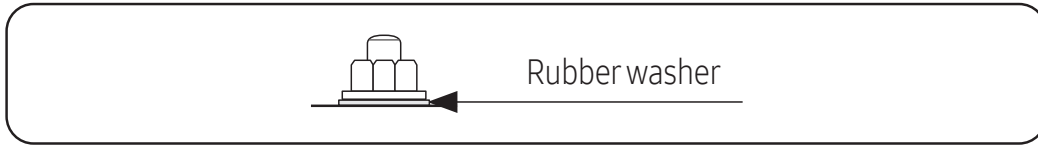

- Anchor specification

Size	Diameter of drill bit (a)	Anchor length (b)	Sleeve length (c)	Insert depth	Fastening torque
Ø 10	14 mm	75 mm	40 mm	50 mm	30 N·m

- ※ Use the anchor bolts and nuts that is zinc plated or made of STS material. Regular anchor bolts or nuts may get damaged by corrosion.

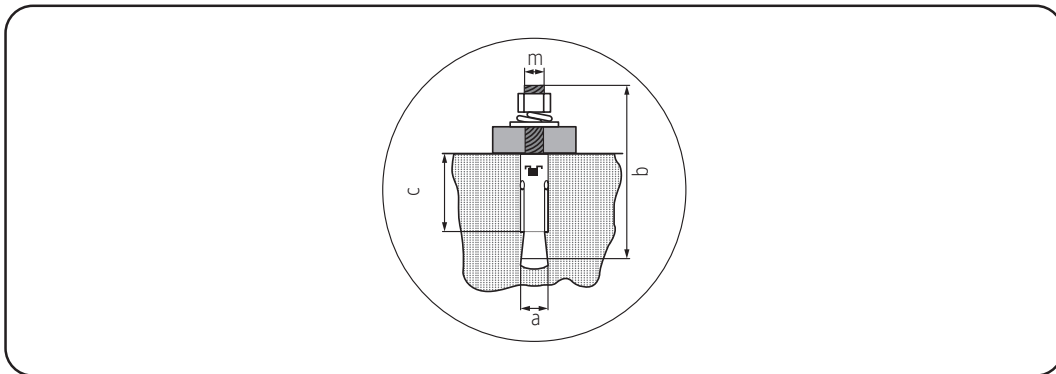

- Cautions regarding on connecting the pipe
 - If you install the outdoor unit on the rooftop, check the strength and make sure to waterproof the rooftop.
 - Construct draining pit around the base construction and pay attention to the drainage around the outdoor unit. (Condensation or defrost water may form during outdoor unit operation.)
 - If there's any possibility of small animals from entering the pipe outlet, block the outlet as shown in the illustration.

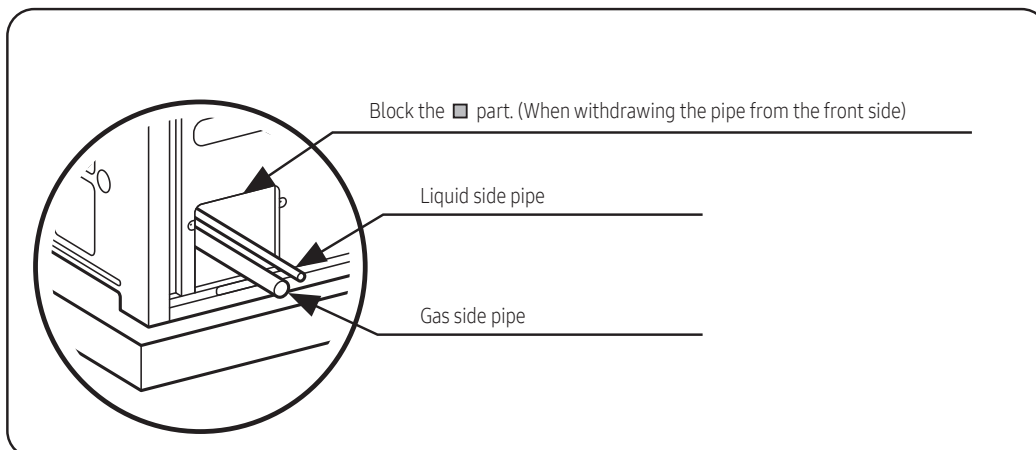

※ Installation

- Cautions regarding on anti-vibration frame installation
 - During installation, make sure there is no gap between the base ground and the supporting structures such as antivibration frame or H beam.
 - Base ground must be constructed strongly to support the bottom part of the anti-vibration mount.

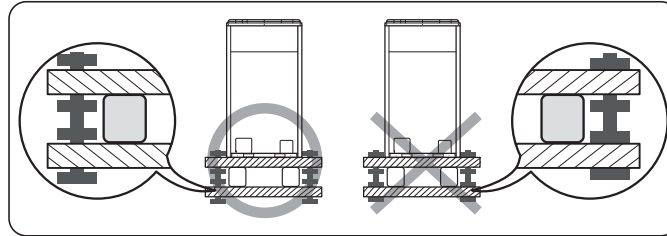

- After installing the anti-vibration frame, untighten the fixing part on the top and bottom part of the frame.
- Caution for installing discharge duct
 - Static pressure of the discharge duct should be within the standard specification when installing the duct.
 - If you remove the fan guard to install the discharge duct, make sure to install a safety net on the duct outlet. Foreign substance may enter into the product and there could be a risk of personal injury.
 - Wear protection equipment at all times when making galvanized sheet metal duct, since the orker may get injured by the sharp parts.
 - When installing the outdoor unit under the tree or near forest, leaves may get into the product and cause problems on the product. Therefore, install a discharge duct to prevent foreign substance infiltration.

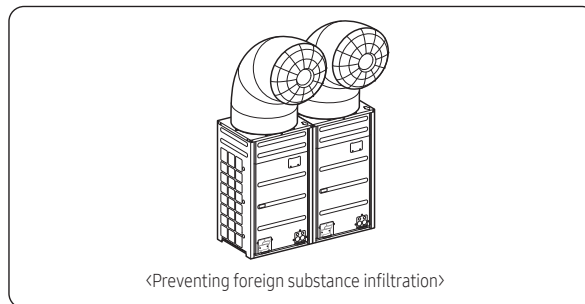

Installing the outdoor unit in various environments

Installing the outdoor unit around the obstacles

- It is necessary to install a discharge guide duct(field supply) to direct exhaust from the fan horizontally, when it is difficult to provide a minimum space of 2m (6.56ft) between the air outlet and a nearby obstacle.

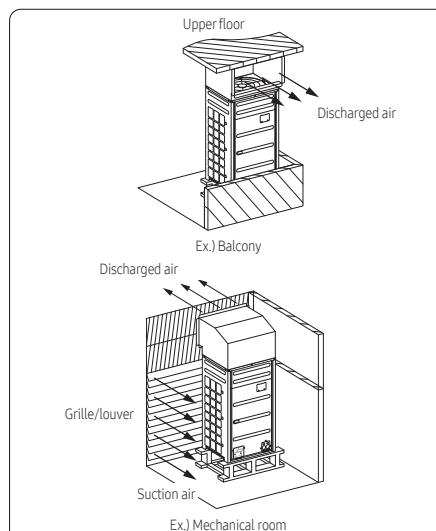

※ Installation

Outdoor unit installation

⚠ WARNING

- Should adopt bar type louver. Don't use a type of rain resistance louver.

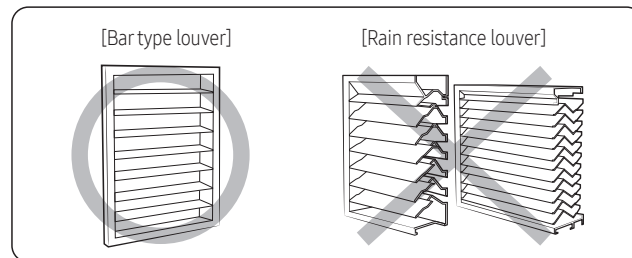

- Louver specifications.
 - Angle criteria : less than 20°
 - Opening ratio criteria : greater than 80%

Installing the outdoor unit in cold region

- In cold regions with lots of snowfall, install a snow prevention duct, as a sufficient countermeasure, to prevent snow from accumulating on the outdoor unit. When the snow prevention duct is not installed, frost may accumulate on the heat exchanger and heating operation may not work normally.
- Air outlet of the duct should not be directed to the enclosed space.

⚠ CAUTION

- Cautions regarding on installing the frame and selecting the base ground
 - Height (h) of the frame and the base ground should be higher than the “heaviest expected snowfall”.
 - Area of the frame and the base ground should not be larger than the are of the outdoor unit. Snow may accumulate if the area of the frame or the base ground is larger.

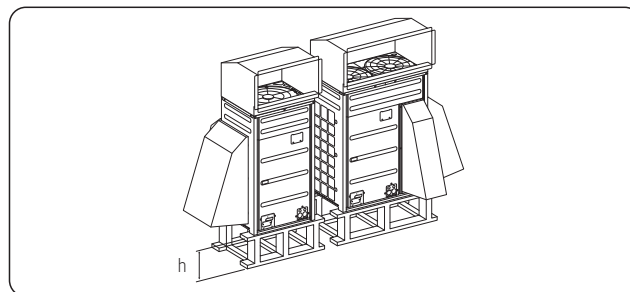

Installing the outdoor unit in windy region

- In windy regions such as near sea shores, protection wall or wind protection duct must be installed for normal operation of the outdoor unit. (Refer to the illustration of the snow prevention duct, for installing the wind protection duct.)
- Install the wind prevention duct with the consideration of major wind direction. If the direction of the discharge part is same as major direction of the wind, it could cause product's performance decrease.

⚠ CAUTION

- Cautions regarding on installing the frame and selecting the base ground
 - The base ground must be solid and the outdoor unit must be fixed with anchor bolts.
 - Make sure to install outdoor unit in a place strong enough to withstand its weight. If the place cannot withstand the weight of the outdoor unit, outdoor unit may fall and cause personal injury.
 - When installing on a rooftop subject to strong wind, countermeasures must be taken to prevent the unit from falling down.
 - Use a frame that is resistant to corrosion.

※ Installation

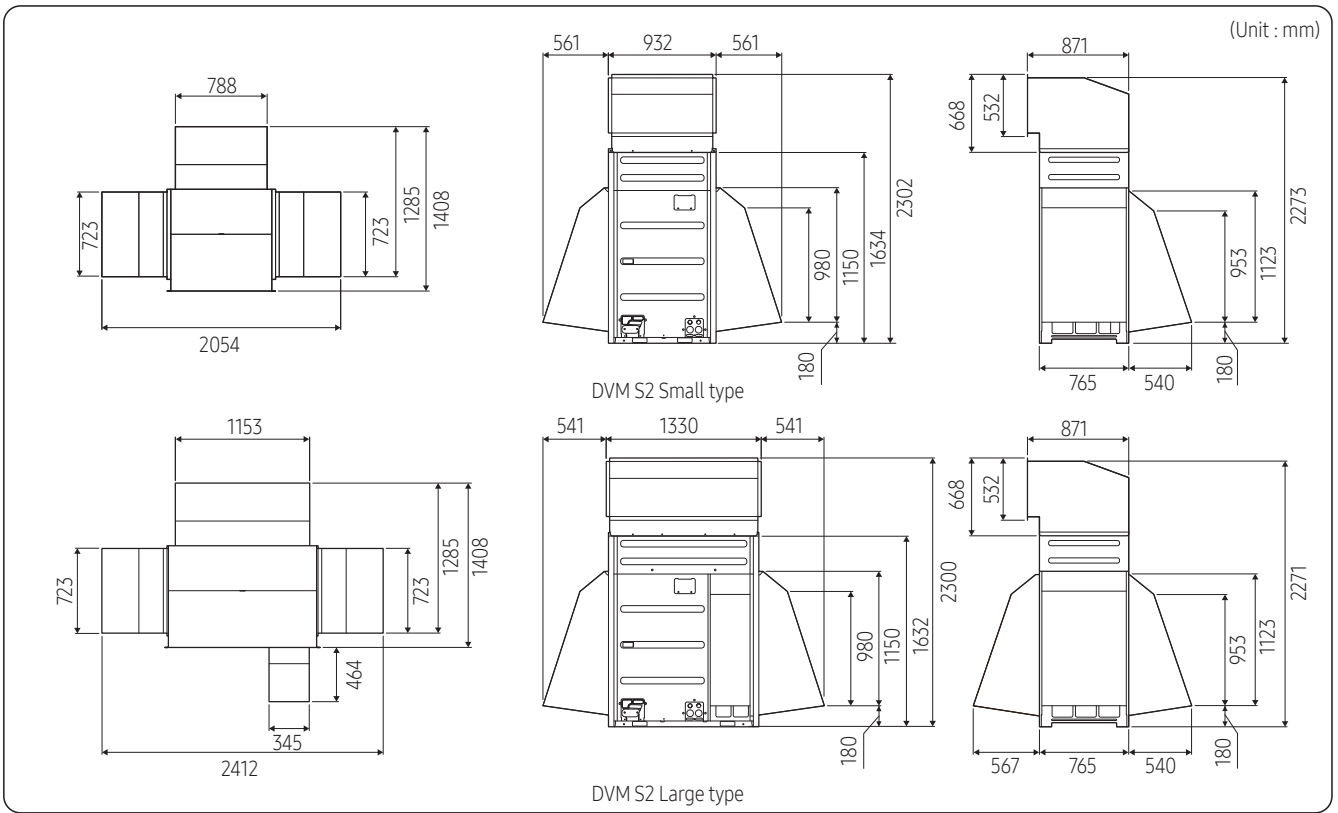

※ Installation

Refrigerant pipe installation



WARNING

- When installing, make sure there is no leakage. When collecting the refrigerant, stop the compressor first before removing the connection pipe. If the refrigerant pipe is not properly connected and the compressor works with the service valve open, the pipe inhales the air and it makes the pressure inside of the refrigerant cycle abnormally high which may lead to explosion and injury.

Refrigerant pipe work

- The length of refrigerant pipe should be as short as possible and the height difference between an indoor and outdoor unit should be minimized.
- Piping work must be done within allowable piping length, height difference, and the allowable length after branching.
- The pressure of the R32 is high. Use only certified refrigerant pipe and follow the installation method.
- After installing the pipes, calculate the total length of the pipe to check if additional refrigerant is needed. When you need to charge the additional refrigerant, make sure to use R32 refrigerant.
- Use clean refrigerant pipe and there shouldn't be any harmful ion, oxide, dust, iron content or moisture inside pipe.
- Use tools and accessories that fit on R32 only.

Tool	Installation process/ purpose		Compatibility with conventional tool
Pipe cutter	Refrigerant pipe installation	Pipe cutting	Compatible
Flaring tool		Pipe flaring	
Refrigerant machine oil		Apply refrigerant oil on flared part	Exclusive ether oil, ester oil, alkali benzene oil or synthetic oil
Torque wrench		Connect flare nut with pipe	Compatible
Pipe bender		Pipe bending	
Nitrogen gas	Air tightness test	Prevent oxidation within the pipe	Compatible
Welder		Pipe welding	
Manifold gauge	Air tightness test ~ additional refrigerant charging	Vacuuming, charging refrigerant and checking operation	Compatible
Refrigerant charging hose			Need exclusive one since there is risk of refrigerant leakage or inflow of impurities
Vacuum pump	Pipe drying		Compatible (Use products which contain the check valve to prevent the oil from flowing backward into the outdoor unit.) Use the one that can be vacuumed up to -100.7kpa(5Torr).
Scale for refrigerant charging	Refrigerant charging		Compatible
Gas leak detector	Gas leak test		Need exclusive one (Ones used for R-134a is compatible)
Flare nut	Must use the flare nut equipped with the product.		

※ Installation

Selecting refrigerant pipe

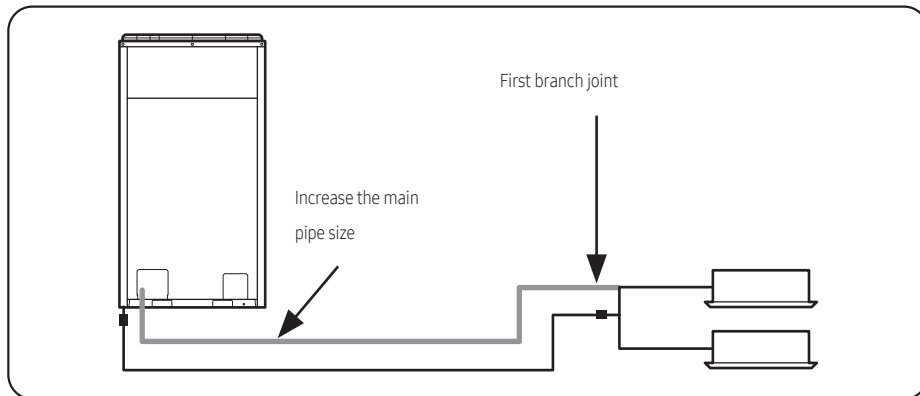

- Install the refrigerant pipe according to main pipe size of each outdoor unit capacity.
 - When the pipe length (including elbow) between an outdoor unit and the farthest indoor unit exceeds 90m, you must increase the size of the pipe (main pipe) by one grade which connects between the outdoor unit to the first branch joint.
-

※ Installation

Ex.) 135.2 kW

Capacity (kW)	No.	Pipe size (mm)	
		Liquid	Gas
33.6	(1)	Ø 12.70	Ø 22.22
73.6	(2)	Ø 15.88	Ø 28.58
135.2	(3)	Ø 19.05	Ø 41.28

Size of the pipe connected to the outdoor unit (A)

Select the size of the main pipe according to the below table.

Outdoor unit capacity (kW) (Cooling)	*Maximum pipe length within 90m		*Maximum pipe length over 90m			
	Liquid (mm)	Gas (mm)	Liquid (mm)	Gas (mm)		
Capacity ≤ 25	Ø 9.52	Ø 19.05	Ø 12.70	Ø 22.22		
25 < Capacity ≤ 29				Ø 25.40 ^{note1)}		
29 < Capacity ≤ 35	Ø 12.70	Ø 22.22	Ø 15.88	Ø 28.58		
35 < Capacity ≤ 41				Ø 28.58		
41 < Capacity ≤ 53					Ø 31.75 ^{note2)}	
53 < Capacity ≤ 65	Ø 15.88	Ø 34.92	Ø 19.05	Ø 34.92		
65 < Capacity ≤ 70				Ø 38.10 ^{note3)}		
70 < Capacity ≤ 80				Ø 41.28	Ø 22.22	Ø 41.28
80 < Capacity ≤ 92						Ø 44.45 ^{note4)}
92 < Capacity ≤ 108	Ø 19.05	Ø 41.28	Ø 22.22	Ø 41.28		
108 < Capacity ≤ 120				Ø 44.45 ^{note4)}		
120 < Capacity ≤ 137	Ø 9.52	Ø 19.05	Ø 12.70	Ø 22.22		
137 < Capacity ≤ 171				Ø 25.40 ^{note1)}		

*Maximum pipe length : The pipe length between an outdoor unit and the farthest indoor unit.
 Note1) If Ø 25.40 pipe is not available on site, use Ø 28.58 pipe.
 Note2) If Ø 31.75 pipe is not available on site, use Ø 34.92 pipe.
 Note3) If Ø 38.10 pipe is not available on site, use Ø 41.28 pipe.
 Note4) If Ø 44.45 pipe is not available on site, use Ø 53.98 pipe.
 ※ For the case that the diameter of the default pipe of an outdoor unit does not match that of the pipe installed on the site, a socket is provided by default together with the outdoor unit.

Branch joint (C-E)

Branch joint between outdoor units (C)
 Select a branch joint according to the sum of the capacity of outdoor units connected to the branch joint.

Classification	Outdoor unit capacity (kW)	Model name
Y-joint for outdoor unit (C)	Capacity ≤ 160	MXJ-TA3419M
	160 < Capacity	MXJ-TA4122M

First branch joint (D)
 Select according to the sum of the capacity of the outdoor unit.

Classification	Outdoor unit capacity (kW)	Model name
Y-joint (D)	Capacity ≤ 50.4	MXJ-YA2512M
	Capacity ≤ 67.2	MXJ-YA2812M
	Capacity ≤ 78.4	MXJ-YA2815M
	Capacity ≤ 123.2	MXJ-YA3419M
	Capacity ≤ 190.4	MXJ-YA4119M
	190.4 < Capacity	MXJ-YA4422M

Branch joint (E)
 Select a branch joint according to the sum of indoor unit capacity which will be connected after the branch.
 ※ However, if the branch joints (E) is bigger than the first branch joint (D), apply the branch joint of the same size as the first branch joint (D).

Classification	Indoor unit capacity (kW)	Model name
Y-joint (E)	Capacity < 16	MXJ-YA1509M
	16 ≤ Capacity < 56	MXJ-YA2512M
	56 ≤ Capacity < 72.8	MXJ-YA2812M
	72.8 ≤ Capacity < 84	MXJ-YA2815M
	84 ≤ Capacity < 123.2	MXJ-YA3419M
	123.2 ≤ Capacity < 196	MXJ-YA4119M
	196 ≤ Capacity	MXJ-YA4422M
Distribution header (E)	Capacity < 56 (for 4 rooms)	MXJ-HA2512M
	Capacity < 100.8 (for 8 rooms)	MXJ-HA3115M
	Capacity < 162.4 (for 8 rooms)	MXJ-HA3819M

※ If the criteria for selecting the branch in the outdoor installation manual and the branch installation manual are different, please select the branch in accordance with the outdoor installation manual.

Size of the pipe between branch joints (B)

Select the pipe size according to the sum of indoor unit capacity which will be connected after the branch.
 ※ However, if the size of the pipe between branch joints (B) is bigger than the size of the pipe connected to the outdoor unit (A), apply the pipe size (A).

Indoor unit capacity (kW)	Branch pipe length within 45m		Branch pipe length between 45-90m			
	Liquid (mm)	Gas (mm)	Liquid (mm)	Gas (mm)		
Capacity ≤ 5.7	Ø 6.35	Ø 12.70	Ø 9.52	Ø 15.88		
5.7 ≤ Capacity < 16	Ø 9.52	Ø 15.88	Ø 12.70	Ø 19.05		
16 ≤ Capacity < 23.2				Ø 22.22		
23.2 ≤ Capacity < 33.6	Ø 12.70	Ø 22.22	Ø 15.88	Ø 25.40 ^{note1)}		
33.6 ≤ Capacity < 39.2				Ø 28.58		
39.2 ≤ Capacity < 44.8					Ø 31.75 ^{note2)}	
44.8 ≤ Capacity < 56	Ø 15.88	Ø 34.92	Ø 19.05	Ø 34.92		
56 ≤ Capacity < 67.2				Ø 38.10 ^{note3)}		
67.2 ≤ Capacity < 72.8				Ø 41.28	Ø 22.22	Ø 41.28
72.8 ≤ Capacity < 84						Ø 44.45 ^{note4)}
84 ≤ Capacity < 95.2	Ø 9.52	Ø 19.05	Ø 12.70	Ø 22.22		
95.2 ≤ Capacity < 112				Ø 25.40 ^{note1)}		
112 ≤ Capacity < 123.2	Ø 12.70	Ø 22.22	Ø 15.88	Ø 28.58		
123.2 ≤ Capacity < 140				Ø 31.75 ^{note2)}		
140 ≤ Capacity < 173.6	Ø 15.88	Ø 34.92	Ø 19.05	Ø 34.92		
173.6 ≤ Capacity < 196				Ø 38.10 ^{note3)}		
196 ≤ Capacity < 212.8	Ø 19.05	Ø 41.28	Ø 22.22	Ø 41.28		
212.8 ≤ Capacity < 240.8				Ø 44.45 ^{note4)}		
240.8 ≤ Capacity	Ø 22.22	Ø 53.98	Ø 25.40 ^{note1)}	Ø 53.98		
				Ø 53.98		

Note1) If Ø 25.40 pipe is not available on site, use Ø 28.58 pipe.
 Note2) If Ø 31.75 pipe is not available on site, use Ø 34.92 pipe.
 Note3) If Ø 38.10 pipe is not available on site, use Ø 41.28 pipe.
 Note4) If Ø 44.45 pipe is not available on site, use Ø 53.98 pipe.

Size of the pipe between the branch joint and the indoor unit (F)

Select according to the capacity of the indoor unit.

Indoor unit capacity (kW)	Liquid (mm)	Gas (mm)
Capacity ≤ 6	Ø 6.35	Ø 12.70
6 < Capacity ≤ 16	Ø 9.52	Ø 15.88
16 < Capacity ≤ 23	Ø 9.52	Ø 19.05
23 < Capacity	Ø 9.52	Ø 22.22

※ Installation

Refrigerant pipe installation

When all the following conditions are met, install the main liquid pipe that is one step smaller to reduce piping load and the amount of refrigerant.

Note that the refrigerant for the main liquid pipe must be added by the specified amount upon reduction.

Condition 1: In case the length for vertical piping is less than 40 m

Condition 2: Max. length A \geq Max. piping length / {1 - (vertical piping length * 0,015)}

※ Max. piping length: Piping length between the outdoor unit and the farthest indoor unit (m)

- Length allowed to reduce the diameter of liquid pipe, A (equivalent length)
- When piping is installed with reduction of the diameter of liquid pipe, Please set option 'reduction of the diameter of liquid pipe.'

Capacity (HP)	Below 90 m		Over 90m		Capacity (HP)	Below 90 m		Over 90m	
	Pipe diameter	Max. length (m)	Pipe diameter	Max. length (m)		Pipe diameter	Max. length (m)	Pipe diameter	Max. length (m)
8	This capacity is not supported.		9.52	200	36	12.70	60	15.88	180
10	This capacity is not supported.		9.52	130	38	12.70	50	15.88	160
12	9.52	90	12.70	200	40	12.70	50	15.88	140
14	9.52	70	12.70	200	42	12.70	40	15.88	130
16	9.52	50	12.70	200	44	15.88	90	19.05	200
18	9.52	40	12.70	200	46	15.88	90	19.05	200
20	9.52	30	12.70	170	48	15.88	90	19.05	200
22	9.52	30	12.70	150	50	15.88	90	19.05	200
24	9.52	20	12.70	120	52	15.88	90	19.05	200
26	12.70	90	15.88	200	54	15.88	80	19.05	200
28	12.70	90	15.88	200	56	15.88	80	19.05	200
30	12.70	80	15.88	200	58	15.88	70	19.05	200
32	12.70	70	15.88	200	60	15.88	70	19.05	200
34	12.70	60	15.88	200					

e.g. In case of the site for 20HP, Max. piping length of 140 m (Horizontal piping length of 120 m & Vertical piping length of 20 m):

Max. length A \geq Max. piping length / {1 - (Vertical piping length * 0.015)}

$200 \text{ m} \geq 140 \text{ m} / \{1 - (20 * 0.015)\} = 140 \text{ m} / 0.7 = 200 \text{ m}$

Thus, the Max. piping length of 140 m (Horizontal piping length of 120 m & Vertical piping length of 20 m) can be allowed.

Accordingly, horizontal piping of 120 m + vertical piping of 20 m (140 m in total) can be installed.

✳ Installation

Additional refrigerant

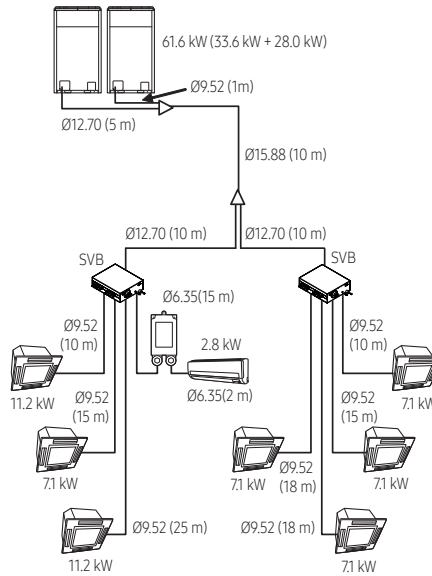

Refrigerant pipe installation

- Basic amount of refrigerant within the outdoor unit (kg)
 - Amount of additional refrigerant has to be calculated based on the sum of all liquid pipe length.

Classification	AM080HCVANG	AM100HCVANG	AM120HCVANG	AM140HCVANG	AM160HCVANG	AM180HCVANG	AM200HCVANG
Basic amount	7.0	7.0	9.3	9.3	10.2	10.2	12.5

- Amount of additional refrigerant depending on the pipe size (Ⓐ)
 - Amount of additional refrigerant has to be calculated based on the sum of all liquid pipe length.

Size of liquid pipe	Ø 6.35	Ø 9.52	Ø12.70	Ø15.88	Ø19.05	Ø 22.22	Ø 25.40	Ø 28.58
Additional amount (kg/m)	0.020	0.055	0.115	0.165	0.245	0.340	0.480	0.590
Amount of refrigerant added when the diameter of liquid pipe is reduced (kg/m)	-	0.07	0.12	0.18	0.27	0.38	0.48	-

- For the indoor unit already connected to EEV kit, the additional refrigerant charging is 0.01kg per meter regardless of the pipe size.

※ Installation

- Amount of additional refrigerant for each indoor unit (㉔)

Model	Refrigerant Amount (kg /Unit)																							
	1.5	1.7	2.2	2.8	3.6	4.5	5.6	6.0	7.1	8.2	9.0	9.3	11.2	12.8	14.0	16.0	18.0	22.4	28.0	32.0	50.0	500CMH	1000CMH	
1way cassette (AM****N1DKG/**)		0.14	0.14	0.23	0.23		0.29		0.29															
4way cassette (600x600) (AM****NNDKG/**)	0.26		0.26	0.26	0.26	0.33	0.33	0.33																
4way cassette (AM****N4DKG/**)				0.41	0.41	0.41	0.54		0.54		0.66		0.66	0.79	0.79									
4way cassette High Sensible (AM****N4FKG/**) (AM****E4FKG/**)			0.66	0.66	0.66	0.66	0.79		0.79		0.79		0.79	0.79	0.79									
360 cassette (AM****N6DKG/**)						0.41	0.41		0.41		0.41		0.62	0.62	0.62									
LSP duct (AM****NLDKG/**) (AM****ELDKG/**)		0.12	0.12	0.12	0.15	0.22	0.22		0.28															
MSP duct (AM****NMDKG/**)			0.41	0.41	0.41	0.41	0.41		0.41		0.61		0.76	0.76	0.76	0.76								
MSP duct High Sensible (AM****NMFKG/**) (AM****EMFKG/**)			0.72	0.72	0.72	0.72	0.76		0.76		0.76		1.04	1.04	1.04									
HSP duct (AM****NHDKG/**) (AM****EHDKG/**)											0.61		0.76	0.76	0.76		1.04	1.06	1.06					
OAP duct (AM****EEDKG/**)															0.61		1.06	1.06						
Ceiling (AM****NCDKG/**)							0.35		0.35				0.50		0.86									
Wall mounted (AM****NVDKG/**) (AM****NQDKG/**)	0.21		0.21	0.29	0.29	0.43	0.43		0.43	0.58		0.61												
Console (AM****EJDKG/**)			0.14	0.24	0.24	0.24	0.24																	
Floor Standing (AM****EFDKG/**) (AM****EPDKG/**)					0.20		0.29		0.29						0.62				1.67					
ERV+ (AM****EKDKG/**)																						0.10	0.32	
Hydro unit HE (AM****EBDKG/**)																0.54				0.63	1.08			
MCU/SVB (*: 1/2/4) (MCU-A*NEK1N) (MSB-A*NEK1N)													0.30											
MCU/SVB (*: 6/8) (MCU-A*NEK1N) (MSB-A*NEK1N)													0.65											
MCU/SVB (*: 12) (MCU-A*NEK1N) (MSB-A*NEK1N)													1.00											

※ If there is no additional refrigerant value for the indoor unit in the above table, refer to the indoor unit installation manual.

- If AHU kit is included among the indoor units, you must add 0.063kg of refrigerant for every 1kW of the AHU capacity increase.

Note1) In case the capacity conjunction of the Hydro Unit HT/HE exceeds 50 % among the total indoor unit, please don't put the additional refrigerant.

- Method to calculate total amount of additional refrigerant
 - Amount of additional refrigerant depending on the pipe length (㉑)
 - Amount of additional refrigerant for each indoor unit (㉔) = Σ (Amount of additional refrigerant for each connected indoor unit) ※ Refer to the table
 - Total amount of additional refrigerant = ㉑+㉔

※ Sum of total amount of additional refrigerant and the basic amount of refrigerant should not exceed 79.56kg.

If the refrigerant exceeds 79.56kg, it goes beyond the scope of the IEC standards, rendering the safety measures we provide ineffective.

Ex> If the outdoor unit's basic refrigerant amount is 10.5kg, the total amount of additional refrigerant(㉑+㉔) should not exceed 69.06kg.

※ Installation

- Example of refrigerant calculation

Classification	Size of liquid pipe	Length (m)	Unit amount of refrigerant (kg/m)	Amount of additional refrigerant (kg)	Total amount of additional refrigerant (kg)
		①	②	①×②	Σ(①×②)
Liquid pipe (a)	Ø 6.35	15	0.02	0.3	a) 11.005
	Ø 9.52	112	0.055	6.16	
	Ø 12.70	25	0.115	2.875	
	Ø 15.88	10	0.165	1.65	
	Ø 6.35 (EEV Kit - indoor unit)	2	0.01	0.02	

Classification	Model name of indoor unit	Number of units	Unit amount of refrigerant (kg/EA)	Amount of additional refrigerant (kg)	Total amount of additional refrigerant (kg)
		①	②	①×②	Σ(①×②)
Indoor unit (b)	4way cassette (AM071DN4DKG*)	5	0.54	2.7	b) 5.61
	4way cassette (AM112DN4DKG*)	2	0.66	1.32	
	Wall mounted (AM028DNVDKG*)	1	0.29	0.29	
	MCU (MCU-A6NEK1N)	2	0.65	1.30	

- Total amount of refrigerant (a+b) = 11.005+5.61 = 16.615 (kg)

※ Installation

Refrigerant pipe installation

Pipe installation for an outdoor unit

- 1 Direction of the pipe Refrigerant pipe can be withdrawn from the front, left and right side. Take necessary method to install the pipes according to the condition of the installation site.

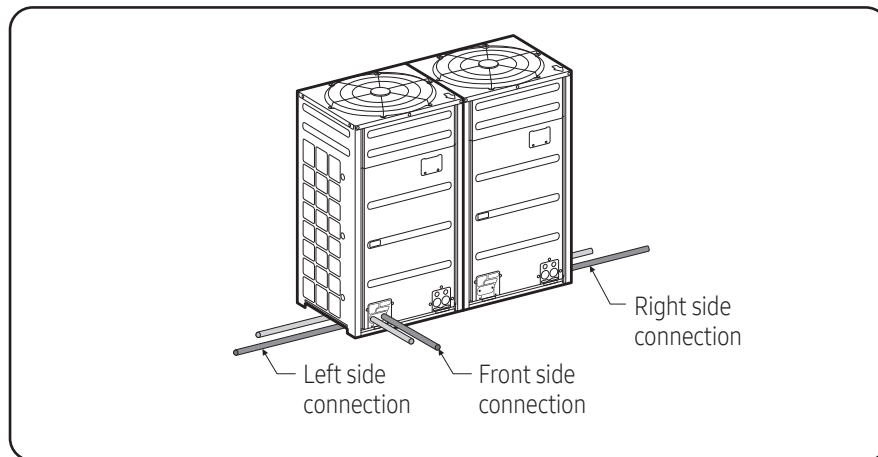

⚠ CAUTION

- Caution for using knock-out hole

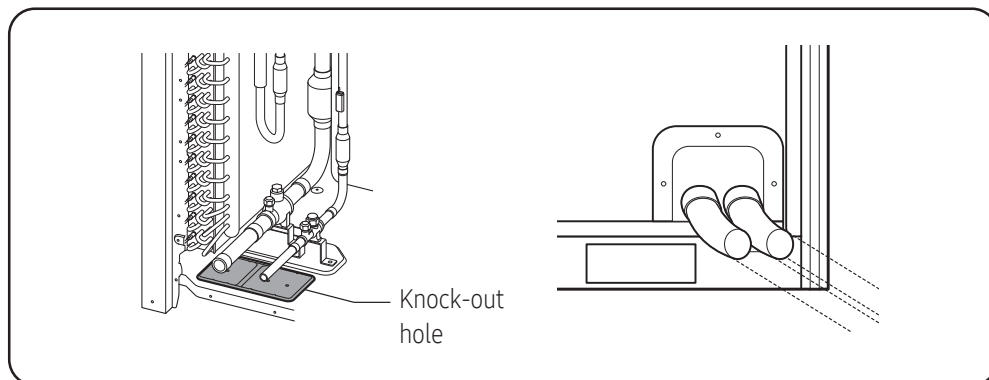

- Make sure to prevent any damages on the exterior of the outdoor unit.
- Remove all burrs around the knock-out hole and apply varnish on the cross section and edges of the knock-out hole to prevent rust.
- Use a cable protection tube and bushing to prevent a cable from being damaged when passing through a knock-out hole.

※ Installation

Refrigerant pipe installation

Pipe installation for an outdoor unit

2 Connecting refrigerant pipe for outdoor unit

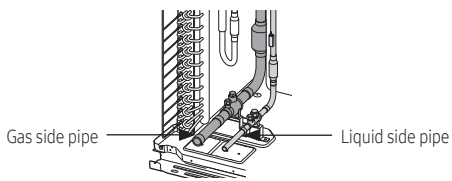
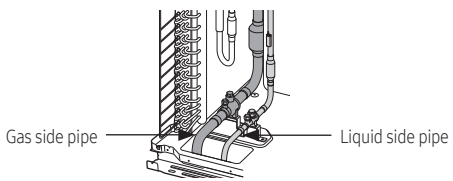
Classification	Front side connection	Right/left (and bottom) side connection
Working process	<ul style="list-style-type: none"> First, remove the piping cover from the outdoor unit. Separate the knock-out hole that you are going to use. If you separate the knock-out hole that is going to be unused, small animals such as squirrels and rats may get into the unit through the hole. Fix the bottom side of the piping cover first and then fix the top part of it. 	<ul style="list-style-type: none"> Separate the knock-out hole at the bottom side of the unit and install the pipe. After installing and insulating the pipe, close up the remaining holes. If not, small animals such as rats and squirrels may get inside the unit.
H/P	 <p>Gas side pipe</p> <p>Liquid side pipe</p>	 <p>Gas side pipe</p> <p>Liquid side pipe</p>

⚠ CAUTION

- Caution for welding the pipe to an outdoor unit
 - When welding the pipe, the unit may get damaged by the heat and flame from welding. Use a flame proofing cloth to protect the unit from a welding fire or flame. Sensor for detecting outside temperature is located on the left side of the welding part so be extra careful not to damage the sensor when welding.
 - The O-ring and Teflon packing inside service valve may get damaged by the heat from welding. Wrap the bottom side of the service valve with a wet cloth and weld it as shown in the illustration. Also, water dripping from the wet cloth may interrupt the welding. Make sure the water does not drip from the wet cloth.
 - Make sure that connected pipes does not interrupt each other or make contact with the product. (Vibration may cause damage to the pipes.)
 - When removing the sealed pipe on the bottom side of the service valve, cut it with a pipe cutter first and then start the welding.
When the sealed pipe is welded without cutting, you may get injured by the refrigerant within the pipe.

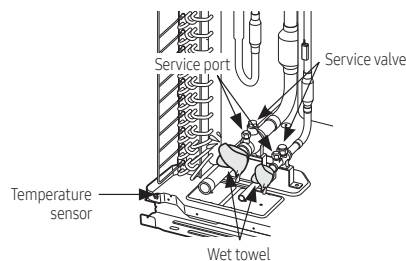

※ Installation

3 Pipe installation between the outdoor units

- You will need branch joints, which is an optional accessory, for connecting in between outdoor units in order to combine outdoor units in module.
 - ※ For optimal distribution of the refrigerant, you must use Y-joint as branch joint for connecting outdoor units. (Do not use T-joint)
- When you install the outdoor units in module, there is no restriction of installation order among outdoor units.
- Height of the connection pipe should be same or lower than the ones connected to the outdoor units.
- Check the changes in comparison with the DVM II, III and IV.

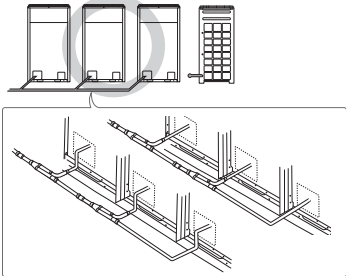
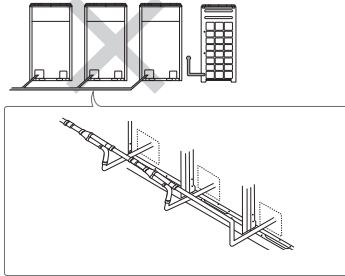
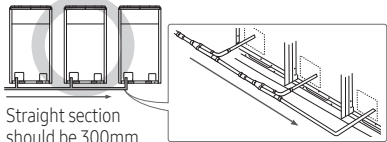
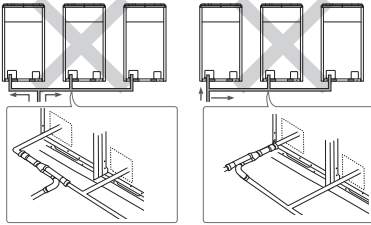
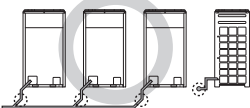
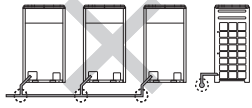
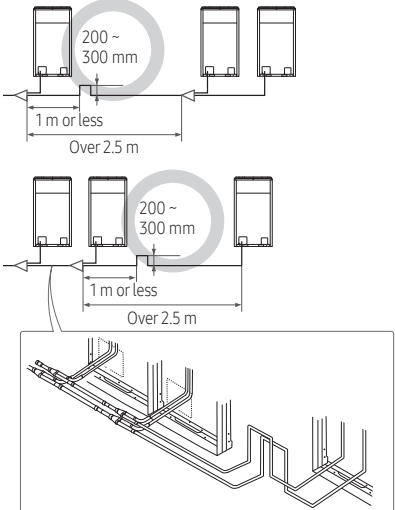
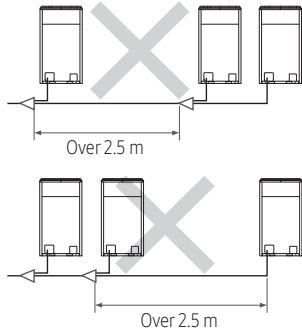
Caution	Correct installation	Incorrect installation
<p>Refrigerant pipes should be connected at the same or lower level than the ones connected to the outdoor unit.</p>		
<p>Refrigerant pipes must be connected by the side of the product.</p>	 <p>Straight section should be 300mm or more</p>	
<p>Branch joint between outdoor units must be installed horizontally.</p>		
<p>Install a vertical trap in following cases as shown in the figure : Case1. Pipe length between outdoor unit branches exceeds 2.5m. Case2. Pipe length between outdoor unit and its branch exceeds 2.5m.</p>		

※ Installation

Refrigerant pipe installation

Examples of refrigerant pipe installation

Using Y-joint

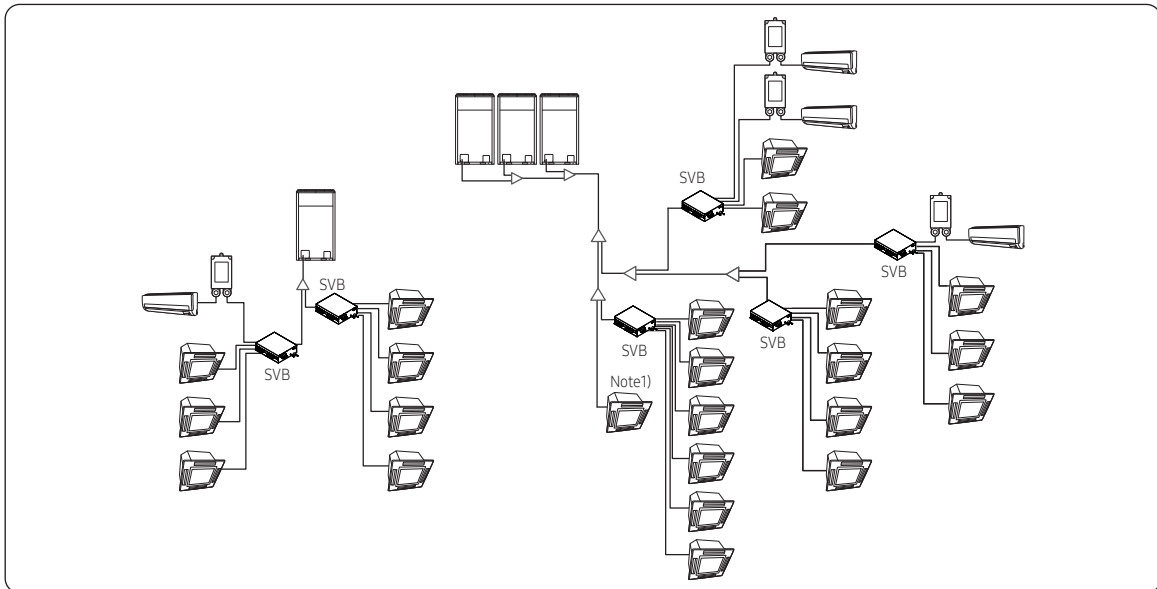

Note 1) Indoor unit without SVB (for HP only)

- Consult a qualified installer to ensure compliance with all safety standards related to refrigerant leakage and to determine whether an SVB connection is required.

※ Installation

Refrigerant pipe installation

Allowable length of the refrigerant pipe and the installation examples

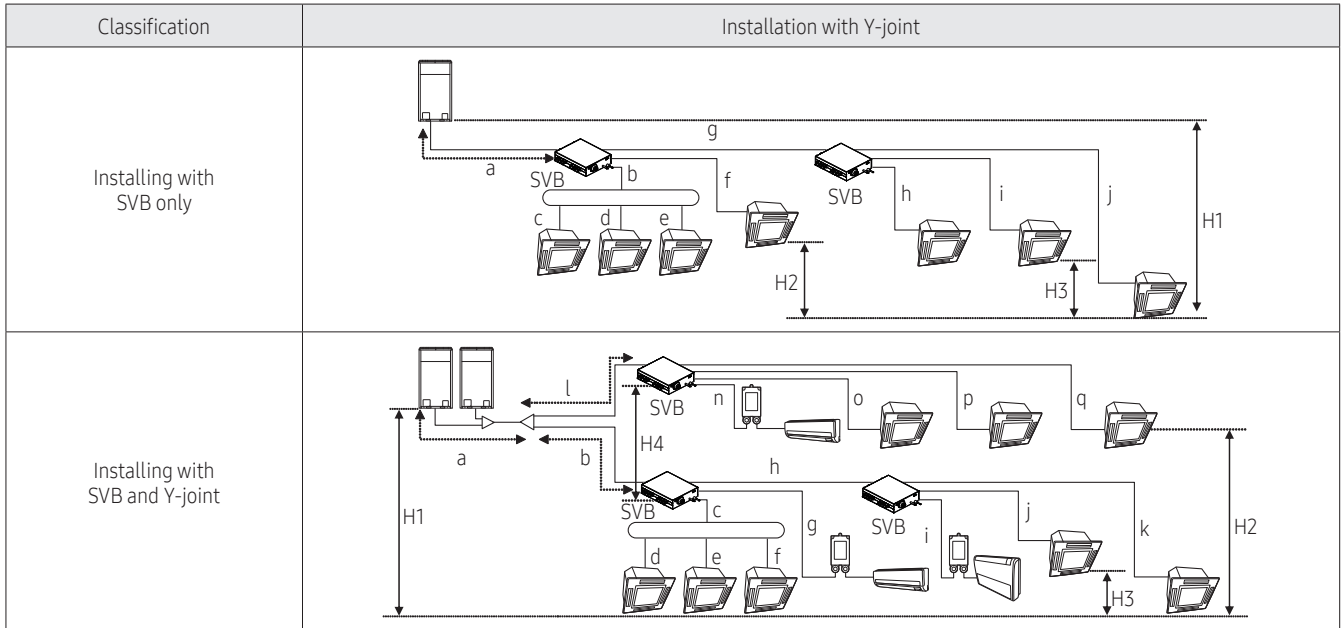

Classification			Example		Remarks	
Maximum allowable pipe length	Outdoor unit ~ Indoor unit	Actual pipe length (Equivalent length)	200 m or less (220 m or less)	Installing only with SVB $a+g+j \leq 200 \text{ m (220 m)}$	Equivalent length Y-joint: 0.5 m Distribution header: 1 m SVB: 1 m	
				Installing with SVB and Y-joint $a+b+h+k \leq 200 \text{ m (220 m)}$		
	Total length of pipe		1000 m or less	Installing only with SVB $a+b+c+d+e+f+g+h+i+j \leq 1000 \text{ m}$		
				Installing with SVB and Y-joint $a+b+c+\dots+r \leq 1000 \text{ m}$		
	Outdoor unit ~ Outdoor unit (Module installation)	Pipe length	10 m or less	$x \leq 10 \text{ m}, y \leq 10 \text{ m}, z \leq 10 \text{ m}$		
		Equivalent length	13 m or less	$x \leq 13 \text{ m}, y \leq 13 \text{ m}, z \leq 13 \text{ m}$		
SVB ~ Indoor unit	Pipe length		45 m or less	Installing only with SVB $b+c \leq 45 \text{ m}, b+d \leq 45 \text{ m}, b+e \leq 45 \text{ m}$ $f \leq 45 \text{ m}, g+h \leq 45 \text{ m}, g+i \leq 45 \text{ m}$ $g+j \leq 45 \text{ m}$		
				Installing with SVB and Y-joint $c+d, c+e, c+f, g, h+i, h+j, h+k, n, o, p, q, \leq 45 \text{ m}$		
Maximum allowable height difference	Outdoor unit ~ Indoor unit	Pipe length	110 m / 110 m <small>Note 1)</small>	$H1 \leq 110 \text{ m / 110 m}$		
	Indoor unit ~ Indoor unit		40 m or less	$H2 \leq 40 \text{ m}$		
	But, when AM****NQD* / AM****NVD* is installed, H2 is 15 m or less.					
	Indoor unit ~ Indoor unit (in one SVB)		15 m or less	$H3 \leq 15 \text{ m}$		
	SVB ~ SVB		30 m or less	$H4 \leq 30 \text{ m}$		
Maximum allowable length after branch joint	First branch joint ~ Farthest Indoor unit	Pipe length	45 m or less	Installing only with SVB $g+j \leq 45 \text{ m}$		
				Installing with SVB and Y-joint $b+h+k \leq 45 \text{ m}$ $l+q \leq 45 \text{ m}$		
			45 ~ 90 m <small>Note 2)</small>	Required conditions must be satisfied		

※ Installation

Refrigerant pipe installation

EEV Kit		Model name		Remarks	
EEV kit ~ Indoor unit	Actual pipe length	2 m	MEV-E24SA	Apply to products without EEV (Wall mount & ceiling)	
			MEV-E32SA		
	20 m or less		MXD-E24K132A		2 indoor
			MXD-E24K200A		
			MXD-E32K200A		
			MXD-E24K232A		3 indoor
			MXD-E24K300A		
			MXD-E32K222A		
	MXD-E32K300A				

※ Please refer to the EEV Kit manual.

Note 1) When indoor unit is located at higher level than outdoor unit, allowable height difference is 110m, (If the height difference is over 40m, contact your local dealer for more information.) but when the indoor unit is located at lower level than outdoor unit, allowable height difference is 110m (If the height difference is over 50m, need to decide whether to install PDM kit or not.)

Model name of the PDM kit : MXD-A38K2A, MXD-A12K2A, MXD-A58K2A

Note 2) Required condition

Classification	Condition	Example
First branch joint ~ Farthest Indoor unit	$45\text{ m} \leq b+h+k, l+q \leq 90\text{ m}$: Size of the branch liquid and low pressure gas pipes (b, l) must be increased by 1 grade.	
Total length of extended pipe	If the size of pipe (main pipe), between the first branch joint and the outdoor unit, is not increased by 1 grade, $a+(b+l)x2+c+d+e+f+g+h+i+j+k+n+o+p+q \leq 1000\text{ m}$	
	If the size of pipe (main pipe), between the first branch joint and the outdoor unit, is increased by 1 grade, $(a+b+l)x2+c+d+e+f+g+h+i+j+k+n+o+p+q \leq 1000\text{ m}$	
SVB ~ Each indoor unit	$c+d, c+e, c+f, g, h+i, h+j, h+k, n, o, p, q \leq 45\text{ m}$	
Difference between the distance of the outdoor unit to the farthest indoor unit and nearest indoor unit ≤ 45 $(a+b+h+k) - (a+b+c+d) \leq 45$		

Note 3) In case of connecting more than one indoor unit in one SVB Port, the below indoor units cannot be combined. ERV plus(AM****EKDKG), OAP duct(AM****EEDKG), Hydro Unit(AM****EBDKG), AHU kit

Note 4) In case of connecting two SVB ports with Y-joint, the indoor units cannot be combined to more than one.

※ Installation

Electrical wiring work

Specification of the circuit breaker and power cable

Standard Type (Heat Pump)

Model	MCA	MFA
AM080HCVANG	18.0	25
AM100HCVANG	23.0	32
AM120HCVANG	25.0	32
AM140HCVANG	29.0	32
AM160HCVANG	32.0	40
AM180HCVANG	39.2	50
AM200HCVANG	43.0	63
AM220HCVANG	48.0	63
AM240HCVANG	52.0	63
AM260HCVANG	57.2	75
AM280HCVANG	62.2	75
AM300HCVANG	64.2	75
AM320HCVANG	68.2	80
AM340HCVANG	71.2	90
AM360HCVANG	78.4	90
AM380HCVANG	82.2	100
AM400HCVANG	86.0	100
AM420HCVANG	89.2	125
AM440HCVANG	96.4	125
AM460HCVANG	101.4	125
AM480HCVANG	103.4	125
AM500HCVANG	107.4	150
AM520HCVANG	110.4	150
AM540HCVANG	117.6	150
AM560HCVANG	121.4	150
AM580HCVANG	125.2	150
AM600HCVANG	129.0	150

- When installing outdoor units in module, select the power supply cable according to the sum of outdoor unit capacity. (Refer to the table for each model)
- Power Supply cords of parts of appliances for outdoor use shall not be lighter than polychloroprene sheathed flexible cord. (Code designation IEC:60245 IEC 66 / CENELEC: H07RN-F) Ex.) AM500*CV***

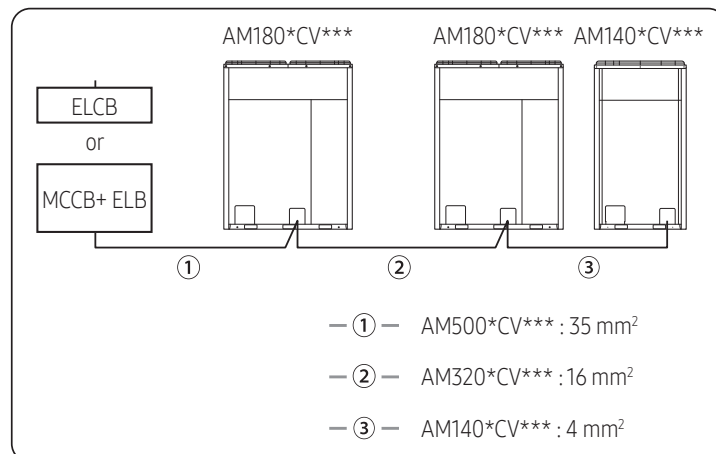

※ Installation

Electrical wiring work

⚠ CAUTION

- Caution for electrical work
 - You must install ELCB or MCCB + ELB
 - ELCB: Earth leakage breaker
 - MCCB: Molded case circuit breaker
 - ELB: Earth leakage breaker
 - Do not operate the outdoor unit before completing the refrigerant pipe work.
 - Do not disconnect or change the cable inside the product. It may cause damage to the product.
 - Specification of the power cable is selected based on following installation condition; culvert installation/ ambient temperature 30 °C/ single multi conductor cables. If the condition is different from the ones stated, please consult an electrical installation expert and re-select the power cable.
 - If the length of power cable exceed 50m, re-select the power cable considering the voltage drop.
 - Use a power cable made out of incombustible material for the insulator (inner cover) and the sheath (outer cover).
 - Do not use the power cable with the core wire exposed due to insulator damage occurred during removal of the sheath. When the core wire is exposed, it may cause fire.

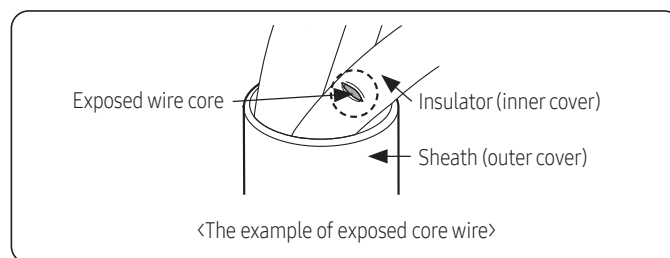

📄 NOTE

- This device is intended for the connection to a power supply system with a maximum permissible system impedance shown in the table (on the left page) at the interface point (power service box) of the user's supply.
- The user must ensure that this device is connected only to a power supply system which fulfills the requirement above. If necessary, the user can ask the public power supply company for the system impedance at the interface point.
- This equipment complies with IEC 61000-3-12 provided that the short-circuit power S_{sc} is greater than or equal to $S_{sc}(*2)$ at the interface point between the user's supply and the public system. It is the responsibility of the installer or user of the equipment to ensure, by consultation with the distribution network operator if necessary, that the equipment is connected only to a supply with a short-circuit power S_{sc} greater than or equal to $S_{sc}(*2)$.

[$S_{sc}(*2)$]

Model	$S_{sc}(\text{MVA})$
AM080HCVANG	3.0
AM100HCVANG	3.7
AM120HCVANG	4.0
AM140HCVANG	4.6
AM160HCVANG	5.2
AM180HCVANG	6.3
AM200HCVANG	7.0

※ Installation

Electrical wiring work

Power and communication cable configuration

- Main power and the ground cable must be withdrawn through the knock-out hole on the bottom-right or right side of the cabinet.
- Withdraw the communication cable from the designated knock-out hole on the bottom-right side of the front part.
- Install the power and communication cable using separate cable protection tube.
- Fix a protection tube to the knock-out hole on the outdoor unit by using a CD connector or bushing. Make sure to use insulating bushing.

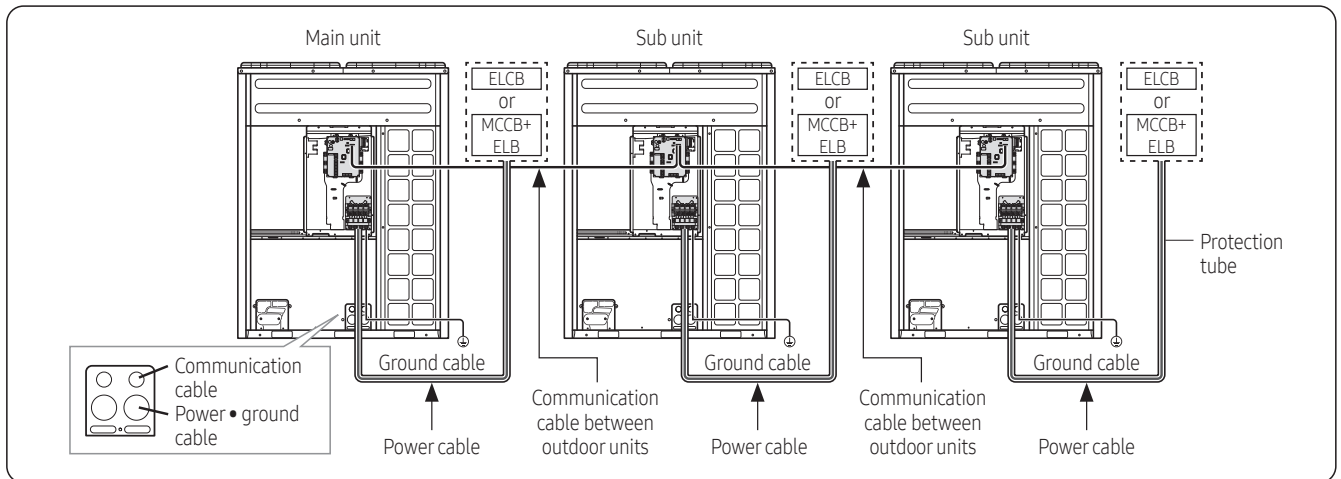

<When the module combination is in the tables of "Outdoor unit combination">

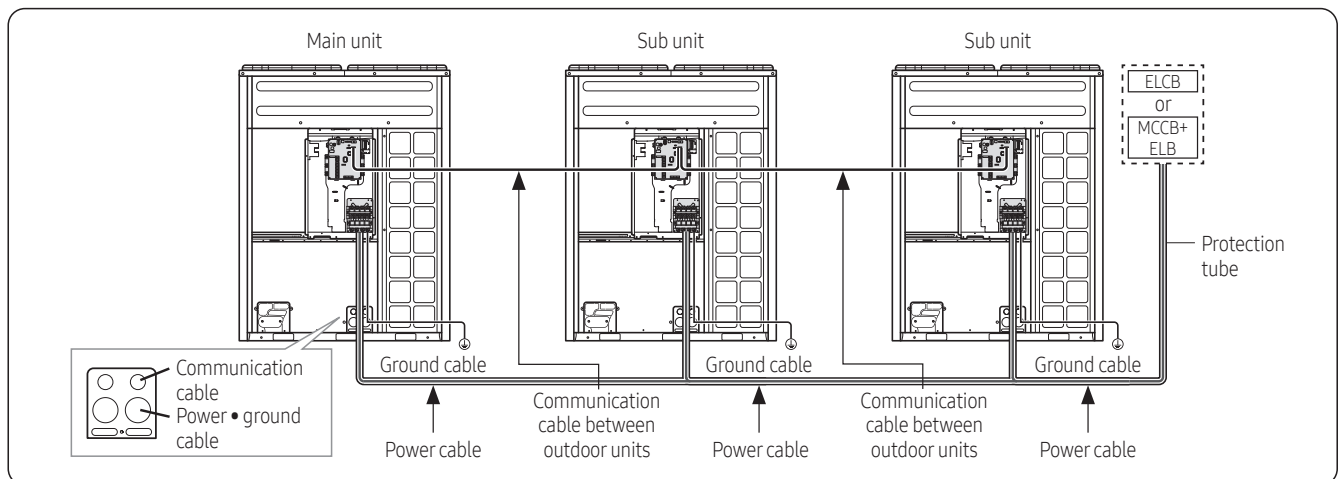

※ Power Supply cords of parts of appliances for outdoor use shall not be lighter than polychloroprene sheathed flexible cord. (Code designation IEC:60245 IEC 66 / CENELEC: H07RN-F)

※ Installation

Specification of the protection tube

Name	Temper grade	Applicable conditions
Flexible PVC conduit	PVC	When the protection tube is installed indoor and not exposed to outside, because it is embedded in concrete structure
Class 1 flexible conduit	Galvanized steel sheet	When the protection tube is installed indoor but exposed to outside so there are risk of damage to the protection tube
Class 1 PVC coated flexible conduit	Galvanized steel sheet and Soft PVC compound	When the protection tube is installed outdoor and exposed to outside so there are risk of damage to the protection tube and extra waterproof is needed

CAUTION

- Caution for perforating the knock-out hole
- Perforate a knock-out hole by punching it with a hammer
- After perforating the knock-out hole, apply rust resisting paint around the hole.
- When you need to pass the cables through the knock-out hole, remove burrs on the hole and protection the cable with a protection tape or bushing etc.
- Caution for installing communication cable
- When you connect the cable, it may sag and pressed by other parts. Therefore cables should be fixed to a clamp highlighted with a box on the illustration.

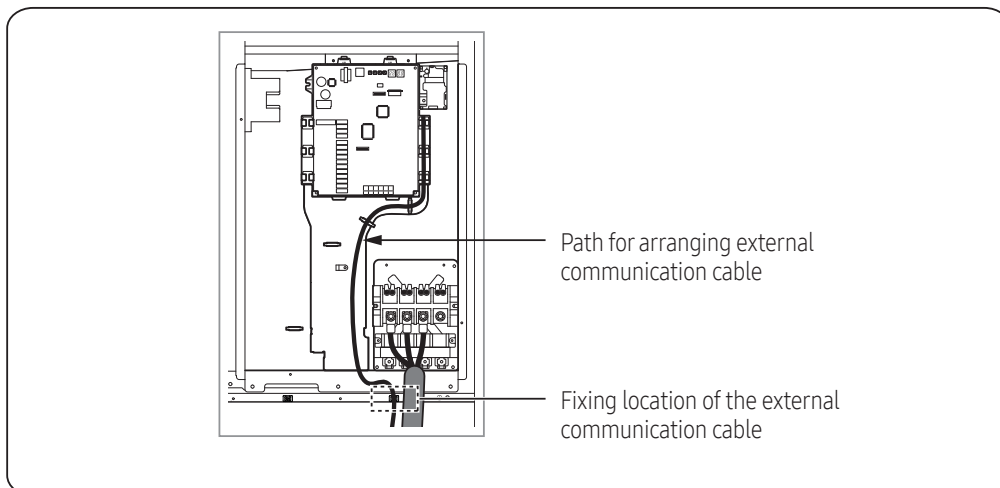

※ Installation

Power wiring diagram

Supplying 3 phase 4 wires (380-415 V~)

<When the module combination is in the tables of "Outdoor unit combination">

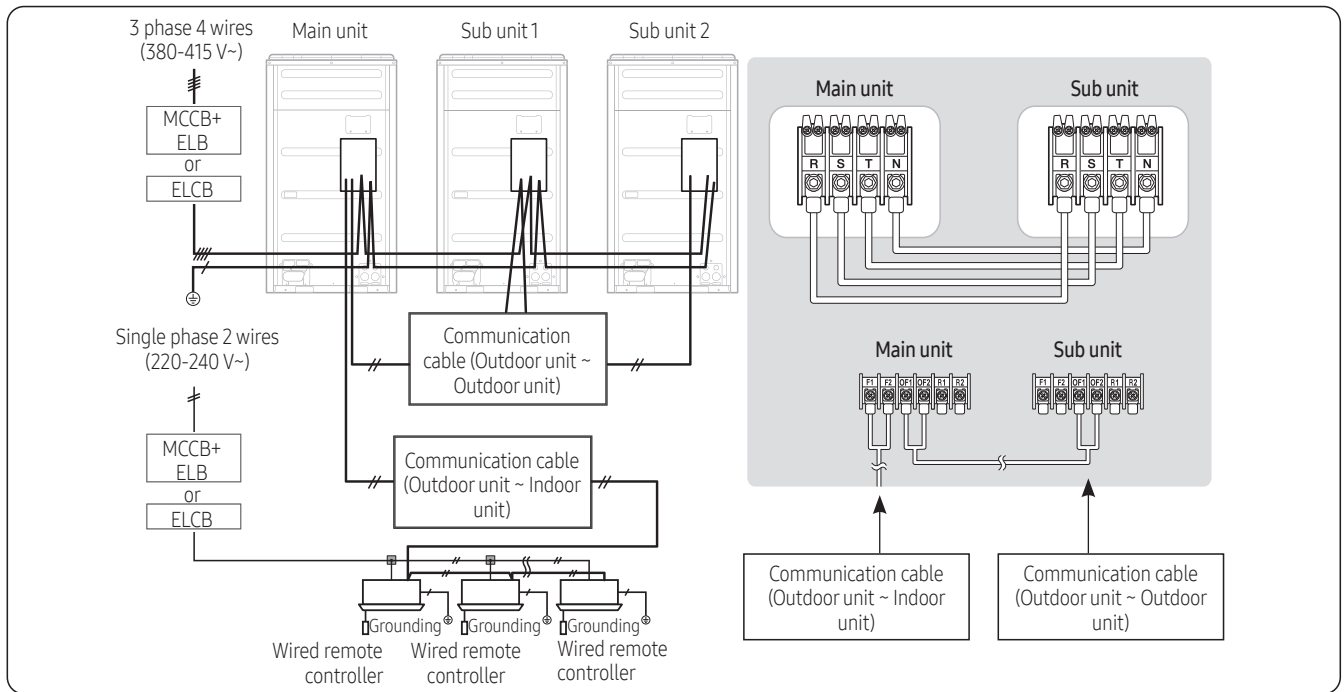

<When the module combination is not in the tables of "Outdoor unit combination">

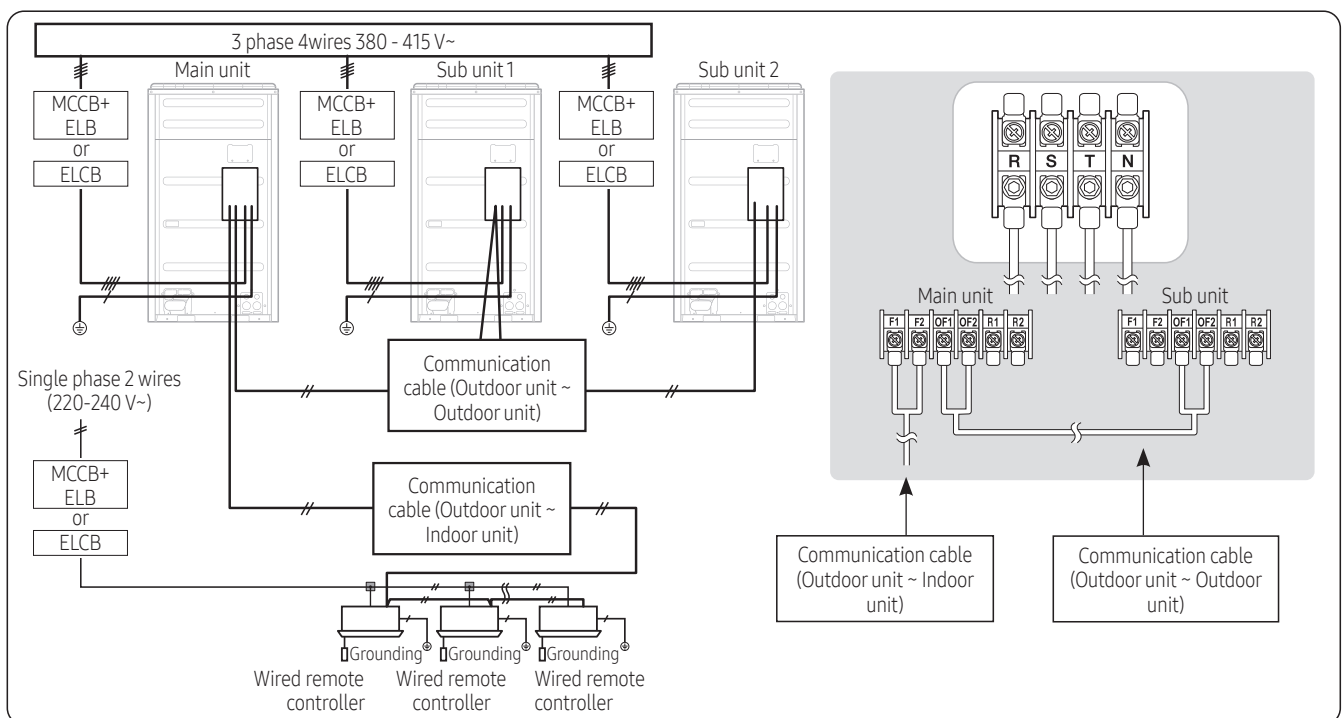

- Connect a power cable of the outdoor unit after checking that R-S-T-N (3 phase 4 wire) is properly connected. (If the 380-415 V power is supplied to the N phase, PCB and other electrical part will be damaged.)
- Communication cable between indoor and outdoor units and communication cable between outdoor units has no polarity.
- Arrange the cables with a cable tie.
- ※ ELCB and ELB must be installed since there is risk of electric shock or fire when they are not installed.

※ Installation

Selecting solderless ring terminal

- Select a solderless ring terminal for a power cable according to the nominal dimensions for cable.
- Apply insulation coating to the connection part of the solderless ring terminal and the power cable.

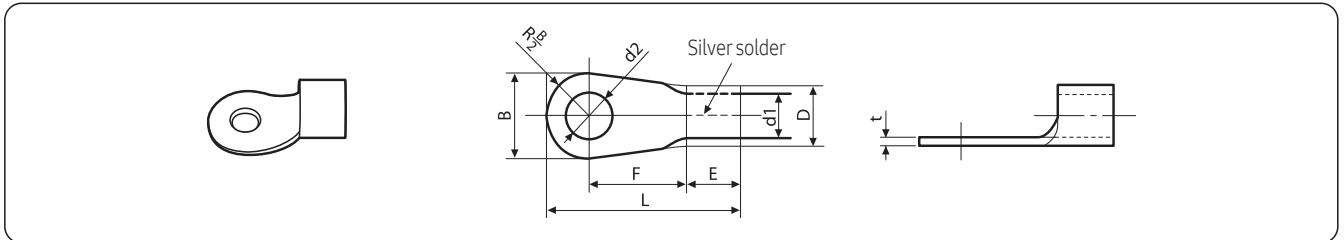

Nominal dimensions for cable (mm ²)		4/6		10	16	25		35		50	70
Nominal dimensions for screw (mm)		4	8	8	8	8	8	8	8	8	8
B	Standard dimension (mm)	9.5	15	15	16	12	16.5	16	22	22	24
	Allowance (mm)	±0.2		±0.2	±0.2	±0.3		±0.3		±0.3	±0.4
D	Standard dimension (mm)	5.6	7.1	9	11.5	13.3		13.5	17.5		
	Allowance (mm)	+0.3 -0.2	+0.3 -0.2	+0.3 -0.2	+0.5 -0.2	+0.5 -0.2		+0.5 -0.2	+0.5 -0.2	+0.5 -0.4	
d1	Standard dimension (mm)	3.4	4.5	5.8	7.7	9.4		11.4	13.3		
	Allowance (mm)	±0.2		±0.2	±0.2	±0.2		±0.2	±0.3	±0.4	
E	Min. (mm)	6		7.9	9.5	11		12.5	17.5	18.5	
F	Min. (mm)	5	9	9	13	15	13	13	13	14	20
L	Max. (mm)	20	28.5	30	33	34		38	43	50	51
d2	Standard dimension (mm)	4.3	8.4	8.4	8.4	8.4	8.4	8.4	8.4	8.4	8.4
	Allowance (mm)	+0.2 0	+0.4 0	+0.4 0	+0.4 0	+0.4 0		+0.4 0	+0.4 0	+0.4 0	+0.4 0
t	Min. (mm)	0.9		1.15	1.45	1.7		1.8	1.8	2.0	

※ Installation

Connecting the power terminal

- Connect the cables to the terminal board with solderless ring terminals.
- Properly connect the cables by using certified and rated cables and make sure to fix them properly so that external force is not applied to the terminal.
- Use a driver and wrench that can apply the rated torque when tightening the screws on the terminal board.
- Tighten the terminal screws by complying rated torque value. If the terminal is loose, fire can occur due to arc heat generation and if the terminal is too tight, terminal board could get damaged.

1 Front connection

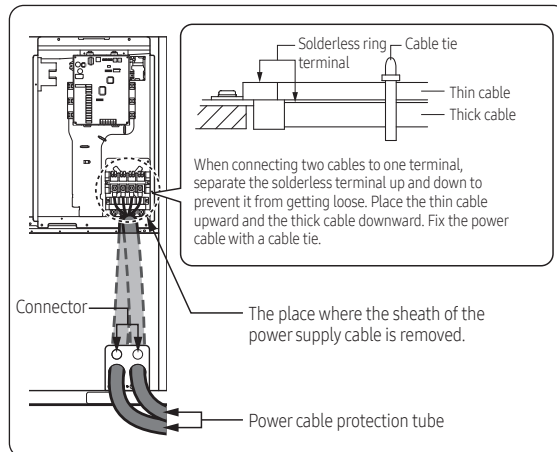

2 Closing the cover

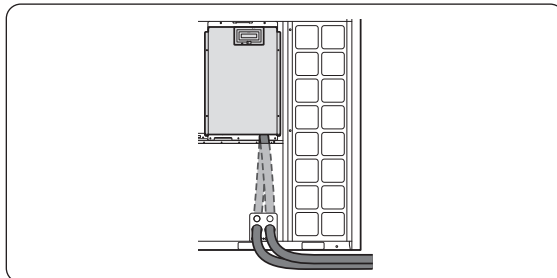

Screw	Tightening torque for terminal (N·m)	
M3.5	0.78-1.18	Communication cable
M4	1.2-1.8	Single phase (220-240 V) power cable
M8	5.5-7.3	3 phase (380-415 V) power cable

⚠ CAUTION

- When removing the outer sheath of the power supply cable, be careful not to scratch the inner sheath of the cable.
- Make sure that more than 20mm of the outer sheath of the indoor unit power and communication cable are inside the electrical component box.
- Install the communication cable separately from power cable and other communication cables.
- There is a risk of electric shock when power is applied. Close the cover of the control box before proceeding to work.
- To inspect the compressor or PBA, first make sure to turn off the system. Electricity may flow even in a compressor that has not been used recently. Exercise caution to protect yourself from an electric shock.

※ Installation

Fixing the power cable

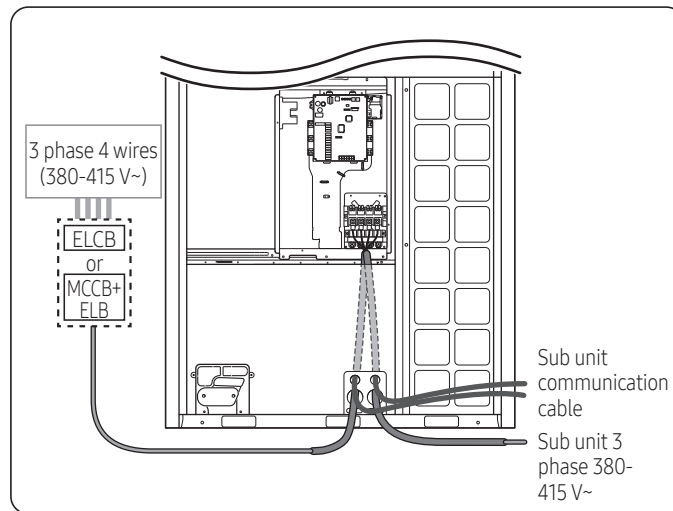

⚠ CAUTION

- Do not let the power cable come into contact with the pipes inside the outdoor unit. If the power supply cable touches the pipes, the vibration of the compressor is transferred to the pipes and can damage the power supply cables or pipes, creating the danger of fire or explosion.
- Make sure that the place where the sheath of power supply cable is removed is inside the power supply box. If it is impossible, you should connect the protection tube for power cable to the power supply box.
- After arranging the power cable into the power supply box, tighten the cover.

※ Installation

Connect the ring terminal of 3 phase cable

- 1 Cut the power cable to an appropriate length and connect it with the solderless terminal.
- 2 After connecting the power cable to the terminal as seen in the illustration, fix it with cable tie.
- 3 Fix the housing, which has an insulator, to the terminal board.

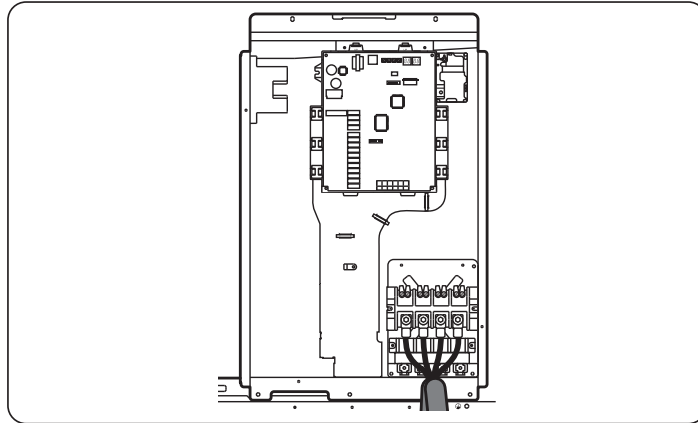

Fixing the ground cable

- Connect the ground cable to the grounding hole inside the power supply box

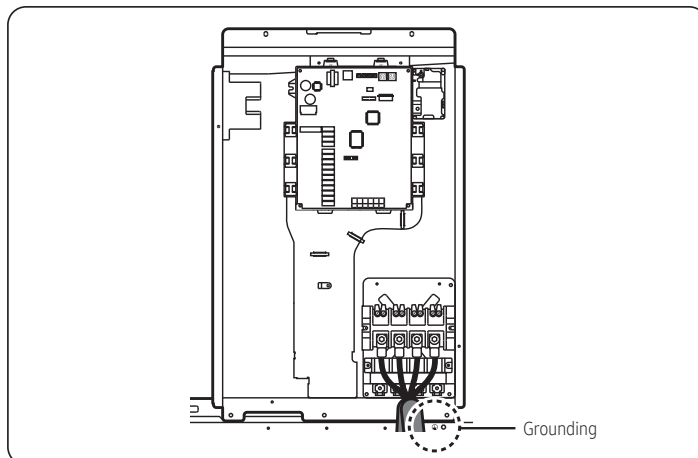

Withdrawing the power cable

- Withdrawing from the front side
 - Connect the power cable protection tube into the power supply box as shown picture.
 - Be sure that the power supply cable is not damaged by burr on the knock-out hole.

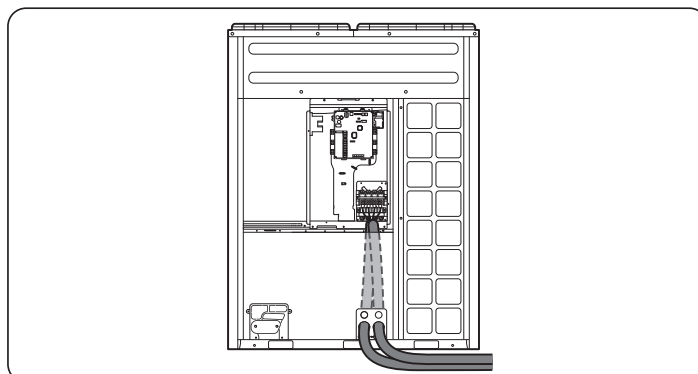

※ Installation

Installing the Solution device

When the number of indoor units installed with the outdoor unit is 16 or less

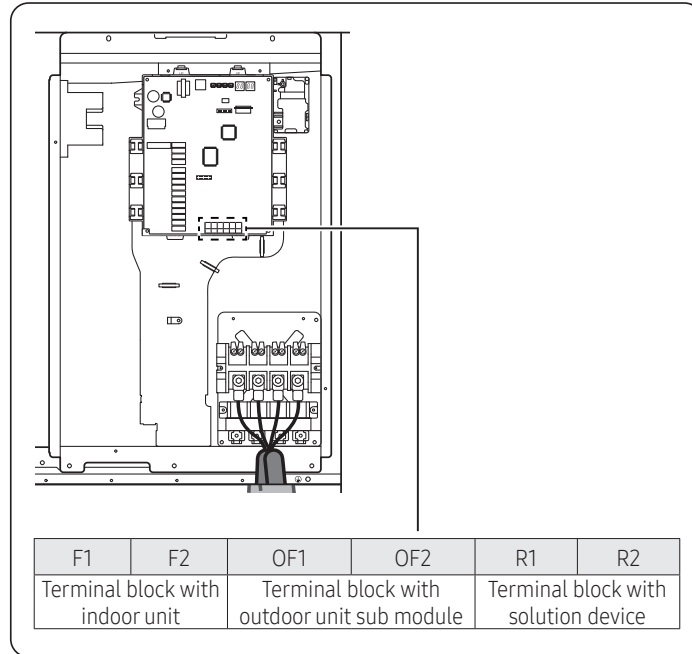

Where to install the interface module

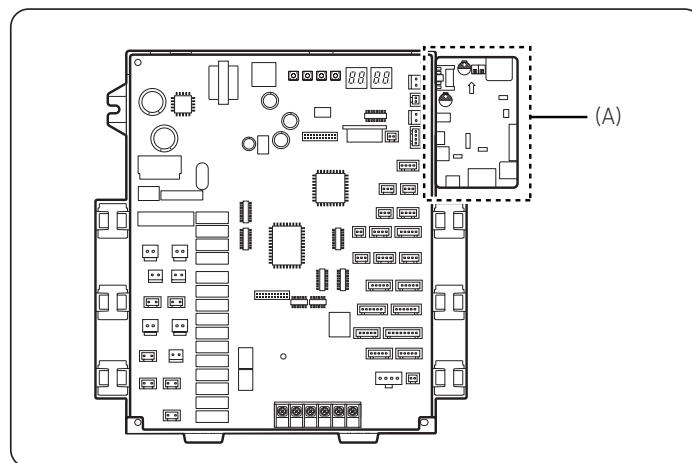

- Install the interface module in location (A), considering the installation conditions.
 - For details on how to install, refer to the interface module installation manual.

✳ Installation

SVB (Shut off Valve Box)

DISCLAIMER: This section is provided as a general guideline to assist with compliance for DVM S2 R-32 system installations. It is not intended to serve as a substitute for a comprehensive code compliance document. The responsibility for ensuring that all designs, installations, and operations meet applicable regulations, codes, and standards rests solely with the project's licensed engineer or other qualified design professional.

The DVM S2 uses R-32, a mildly flammable gas classified as A2L by IEC 60335-2-40. The system is certified as Enhanced Tightness Refrigeration System (ETRS) and allows for connection with shut off valve box and remote-control alarm to alert the users and limit the refrigerant leakage in case of a leak. Follow the installation requirement presented in this manual, and ensure system is compliant with relevance regulations and codes.

Installing the outdoor unit

For full details on outdoor unit installation, see the installation manual supplied with the outdoor unit.

Installing the indoor unit

The space for indoor unit installation is limited. For full details, see the installation manual supplied with the outdoor unit. For full details on indoor unit installation, see the installation manual supplied with the indoor unit.

Installing the SVB

The SVB supports a wide range of safety measures that can be implemented to help meet compliance requirements. For full details on the system's total refrigerant charge, see the installation manual supplied with the outdoor unit. The SVB supplies additional output signals intended for external devices. Such output signals are generated when the indoor unit's R-32 sensor detects a refrigerant leak, or when the R-32 sensor fails or becomes short-circuited. The signals enable additional operations of the ventilation system or alarm.

✳ Installation

SVB (Shut off Valve Box)

Deciding on the Safety Measures for SVB

- Step 1: Determine the system's total refrigerant charge.
Refer to the installation manual supplied with the outdoor unit.
- Step 2: Determine the area of the room the SVB is installed in.
Calculate the area of the room with walls, doors, and partitions excluded.
Spaces connected by false ceilings, ducts, or similar connections are not considered a single space.
- Step 3: Referring to the refrigerant charge and room area determined at Steps 1 and 2, use the graphs and tables below to decide the necessary safety measures.

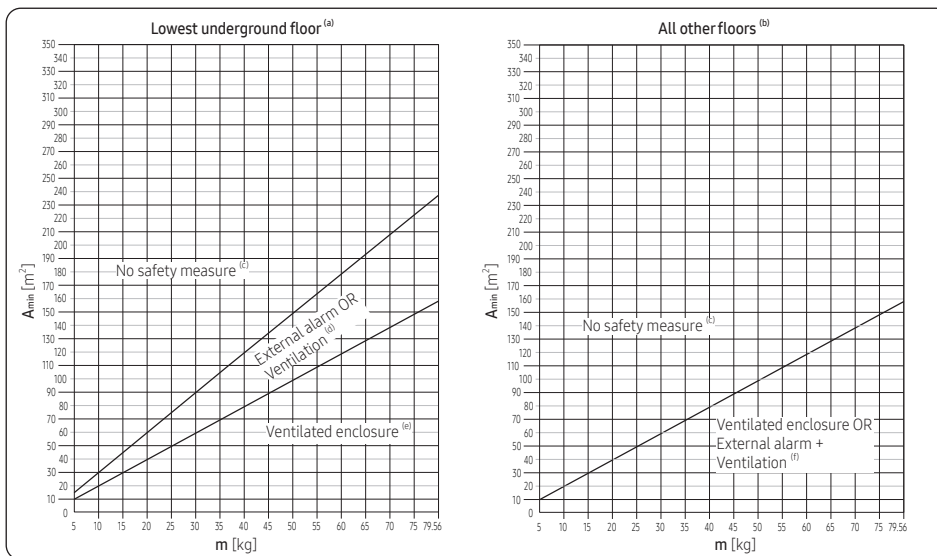

m [kg]	Amin [m ²]		
	Lowest underground floor (a)		All other floors (b)
	No safety measure (c)	External alarm OR Ventilation (d)	No safety measure (c)
5	15	10	10
6	18	12	12
7	21	14	14
8	24	16	16
9	27	18	18
10	30	20	20
11	33	22	22
12	36	24	24
13	39	26	26

m [kg]	Amin [m ²]		
	Lowest underground floor (a)		All other floors (b)
	No safety measure (c)	External alarm OR Ventilation (d)	No safety measure (c)
14	42	28	28
15	45	30	30
16	48	32	32
17	51	34	34
18	53	36	36
19	56	38	38
20	59	40	40
21	62	42	42
22	65	44	44

※ Installation

SVB (Shut off Valve Box)

m [kg]	A _{min} [m ²]		
	Lowest underground floor ^(a)		All other floors ^(b)
	No safety measure ^(c)	External alarm OR Ventilation ^(d)	No safety measure ^(c)
23	68	46	46
24	71	48	48
25	74	50	50
26	77	51	51
27	80	53	53
28	83	55	55
29	86	57	57
30	89	59	59
31	92	61	61
32	95	63	63
33	98	65	65
34	101	67	67
35	104	69	69
36	107	71	71
37	110	73	73
38	113	75	75
39	116	77	77
40	119	79	79
41	122	81	81
42	125	83	83
43	128	85	85
44	131	87	87
45	134	89	89
46	137	91	91
47	140	93	93
48	143	95	95
49	146	97	97
50	149	99	99
51	152	101	101
52	154	103	103
53	157	105	105
54	160	107	107
55	163	109	109
56	166	111	111
57	169	113	113
58	172	115	115
59	175	117	117
60	178	119	119
61	181	121	121
62	184	123	123

m [kg]	A _{min} [m ²]		
	Lowest underground floor ^(a)		All other floors ^(b)
	No safety measure ^(c)	External alarm OR Ventilation ^(d)	No safety measure ^(c)
63	187	125	125
64	190	127	127
65	193	129	129
66	196	131	131
67	199	133	133
68	202	135	135
69	205	137	137
70	208	139	139
71	211	141	141
72	214	143	143
73	217	145	145
74	220	147	147
75	223	149	149
76	226	151	151
77	229	153	153
78	232	154	154
79	235	156	156
79.56	236	158	158

m Total refrigerant charge in the system [kg]

A_{min} Minimum room area [m²]

(a) Lowest underground floor

(b) All other floors

(c) No safety measure

(d) External alarm or Ventilation

(e) Ventilated enclosure

(f) Ventilated enclosure OR External alarm + Ventilation

If the SVB is installed on the building's lowest underground floor, use the first graph (a). For all other floors, use the second graph (b). The graphs and tables were prepared for a SVB installation height of 1.8m to 2.2m.

The installation height refers to the length measured from the underside of the SVB to the floor.

To determine the safety measures required for an installation height greater than 2.2m, consult the appropriate experts or design with DVM PRO 2.0 for accurate results.

The SVB must not be installed at a height lower than 1.8m.

✳ Installation

SVB (Shut off Valve Box)

Flowchart

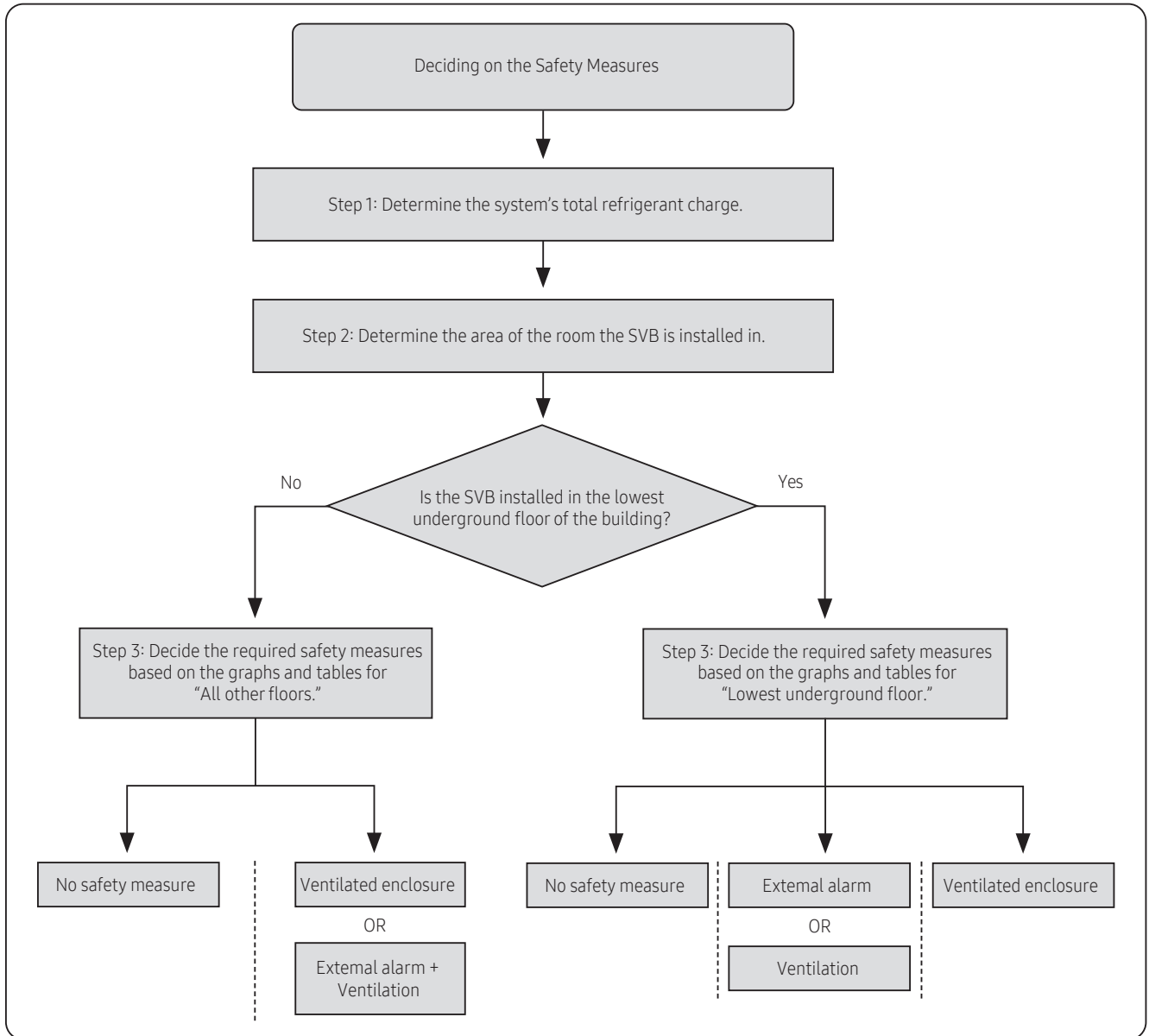

✳ Installation

SVB (Shut off Valve Box)

Safety measures

No safety measure

If the room is of a sufficient size, no particular safety measures are required. This applies to a SVB installed in the lowest underground floor of a building also.

External alarm

If the SVB is installed in an occupied space inaccessible to persons, do not apply safety measures for an external alarm. External alarm circuits must be connected to the SVS output of the SVB. An external alarm system is required to provide auditory and visual alerts. (Example: A buzzer louder than background noise by at least 15 dBA accompanied by a flashing light.) At least one alarm system must be installed for a SVB installed in an occupied space. For any of the below occupied spaces, the alarm system must give additional alerts on supervised location that are monitored 24/7.

- Sleeping facilities
- Presence of an uncontrolled number of persons
- Access by persons unfamiliar with the safety measures

To enable alerts on a supervised location, connect a supervisor remote controller to the system. The supervisor remote controller can be connected to any of the indoor unit of the system, and gives an alert on a supervised location if any of the SVB detects a refrigerant leak.

When the SVB's R-32 sensor detects a refrigerant leak, the SVS output will close and activate the alarm. An error message is displayed on the remote controller of the connected indoor unit.

ventilation

Ventilation is a safety measure involving ventilation through a large space with enough air to dilute leaked refrigerant. Follow the below steps to implement ventilation as a safety measure.

- Step 1: Determine the combined area of the ventilation space and the space where the SVB is installed. Calculate the area of the room with walls, doors, and partitions excluded. Spaces connected by false ceilings, ducts, or similar connections are not considered a single space.
- Step 2: Use the graphs or tables below to determine the limit on the total refrigerant charge of the system.
- (* Round down the calculated value.)

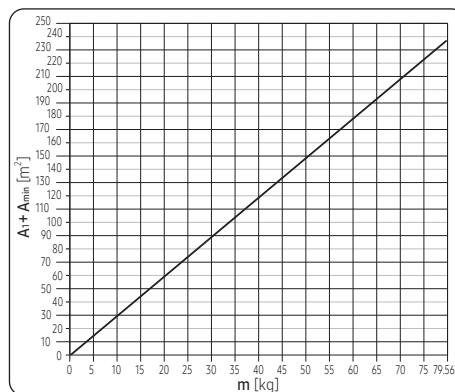

※ Installation

SVB (Shut off Valve Box)

$A_1 + A_{min}$ [m ²]	m [kg]
10	3.3
20	6.7
30	10.1
40	13.5
50	16.8
60	20.2
70	23.6
80	27.0
90	30.3
100	33.7
110	37.1
120	40.5
130	43.9
140	47.2
150	50.6
160	54.0
170	57.4
180	60.7
190	64.1
200	67.5
210	70.9
220	74.2
230	77.6
236	79.56

m Total refrigerant charge in the system [kg]

A₁ Area of the room with natural ventilation [m²]

A_{min} Minimum room area of the space in which the SVB is installed [m²]

The graphs and tables were prepared for a SVB installation height of 1.8m to 2.2m.

The installation height refers to the length measured from the underside of the SVB to the floor.

A higher limit can apply to the total refrigerant charge of the system if the installation height exceeds 2.2m.

To determine the safety measures required for an installation height greater than 2.2m, consult the appropriate experts.

- Step 3: The system's total refrigerant charge must be lower than the refrigerant charge limit calculated from the above graphs. If not, natural ventilation can't be implemented as a safety measure.
- Step 4: The partition between 2 rooms on the same floor must satisfy one of the two conditions for natural ventilation.
 - Rooms on the same floor and with a permanent opening extending to the floor and designed to allow the movement of persons.
 - Rooms on the same floor and with a permanent opening meeting the below requirements, an opening made up of 2 parts to achieve air circulation for natural ventilation.

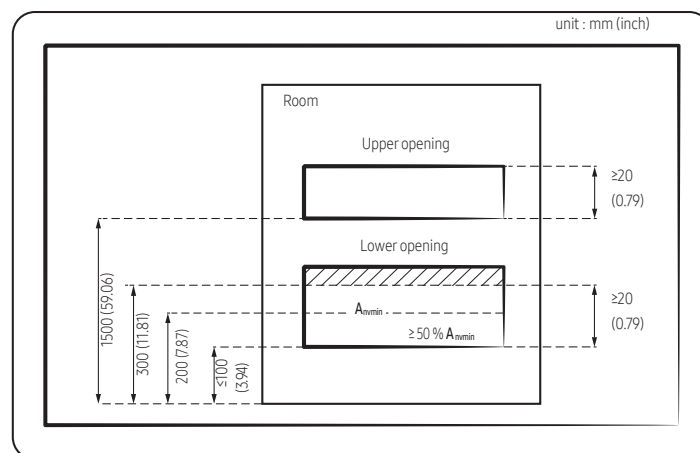

A_{min} Minimal ventilation area

※ Installation

SVB (Shut off Valve Box)

Lower opening:

- Not an opening leading to the outside.
- Not an opening that can be closed.
- Area of the opening is $\geq 0.012 \text{ m}^2$ (Anvmin).
- Area of an opening from the floor that is 300mm or greater is not included in the calculation of Anvmin.
- A minimum of 50% of Anvmin must be located below 200mm from the floor.
- The bottom of the lower opening must be located at $\leq 100\text{mm}$ from the floor.
- The height of the opening is $\geq 20\text{mm}$.

Upper opening:

- Not an opening leading to the outside.
- Not an opening that can be closed.
- The area of the opening is $\geq 0.006 \text{ m}^2$ (50% of Anvmin).
- The bottom of the lower opening must be located at $\geq 1,500\text{mm}$ from the floor.
- The height of the opening is $\geq 20\text{mm}$.

- ※ Upper opening requirements can be satisfied through false ceilings, ventilation ducts, or similar arrangements for airflow between connected rooms.

CAUTION

- Ventilation to outdoors is not allowed below ground level.
- Ventilation from an occupied space shall not be made to outdoors.

Mechanical ventilation

The SVB provides an additional output signal for external devices.

This output signal occurs if the R-32 sensor in the SVB detects a refrigerant leak, or the R-32 sensor has a malfunction or short circuit.

Based on this signal, a mechanical ventilation system can be activated.

If mechanical ventilation is applied, the following conditions must be met to be considered a safety device.

- The upper edge of the air outlet must be located at the same level as or below the refrigerant release point.
 - The mechanical ventilation air extracted from the space must be positioned relative to the mechanical ventilation air intake openings to ensure that the supplementary air mixes with the leaked refrigerant.
 - Required airflow (Please refer to the technical data for the exact required airflow value.)
-

※ Installation

SVB (Shut off Valve Box)

NOTE

- Keep the ductwork from becoming blocked by dust, foreign matter, and small animals.

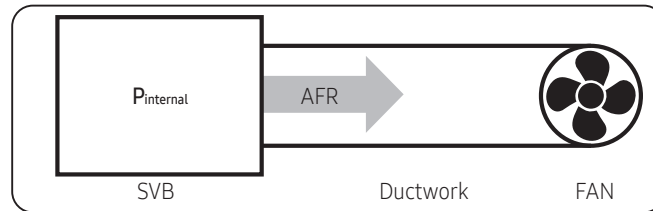

To select the fan of the appropriate specifications, consider the legal requirements and the total pressure drop in the duct system.

The minimum airflow rate required of ductwork by law is 11.1 CFM (18.8 m³/h). The resulting pressure drop must lower the pressure inside the SVB to at least 20 Pa (0.0029 psi) lower than the ambient pressure.

(* The internal pressure of the SVB must not be lower than the ambient pressure by more than 350 Pa (0.0508 psi)).

When treating the total pressure drop in the duct system, calculate the sum of the pressure drops induced by all components of the exhaust channel (e.g. ducts, bends, reducers). If an accurate calculation of pressure drops is required, consult the appropriate experts.

If multiple SVBs are installed, the ductwork can be connected in parallel/serial as shown below.

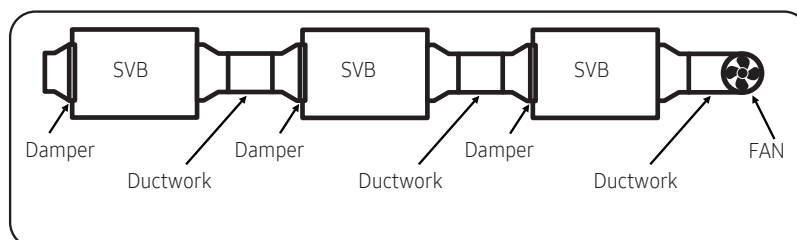
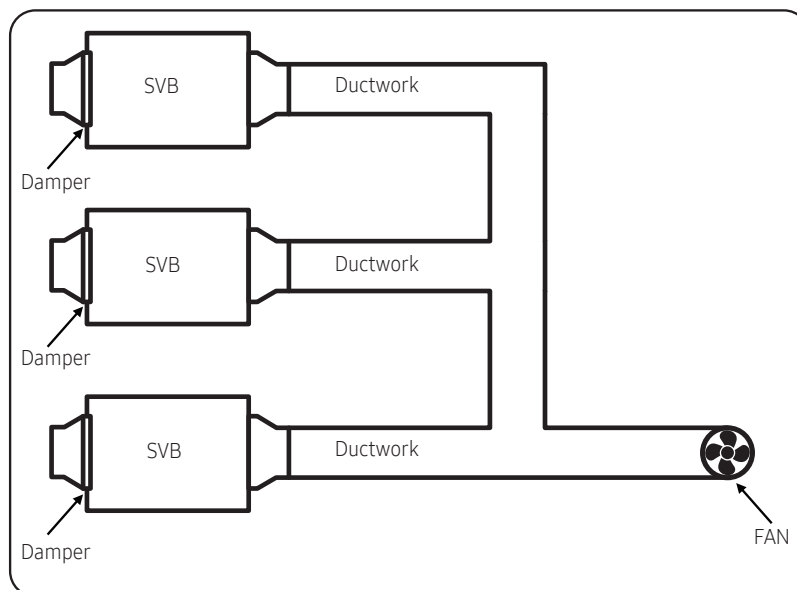

※ Installation

SVB (Shut off Valve Box)

The evacuation channel and the damper must be installed on opposite sides.

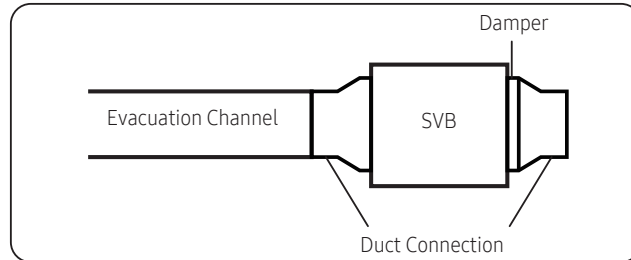

The damper is designed to allow its installation on either side.

If you want to reposition the damper, you need to unscrew and disassemble the damper assembly, then unplug the damper motor wire from the connector and move it. Reassemble the damper assembly on the opposite side and plug the damper motor wire back into the nearest PBA.

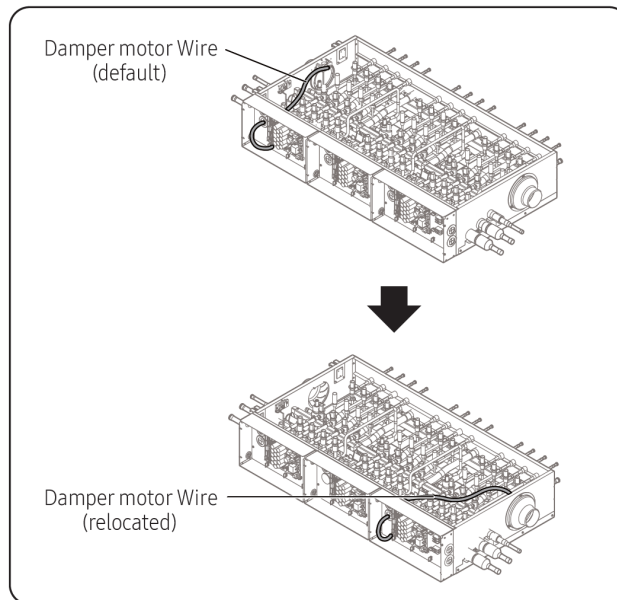

If a ventilated enclosure is not applied as a safety measure, replace the duct connection on the side without the damper with the closing plate provided as an accessory.

It can be replaced by loosening three screws.

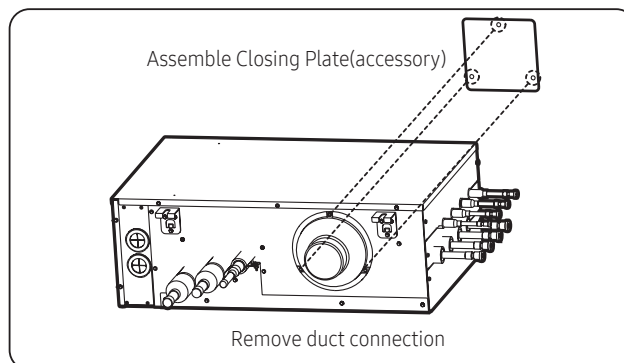

✳ Installation

SVB (Shut off Valve Box)

Flowchart

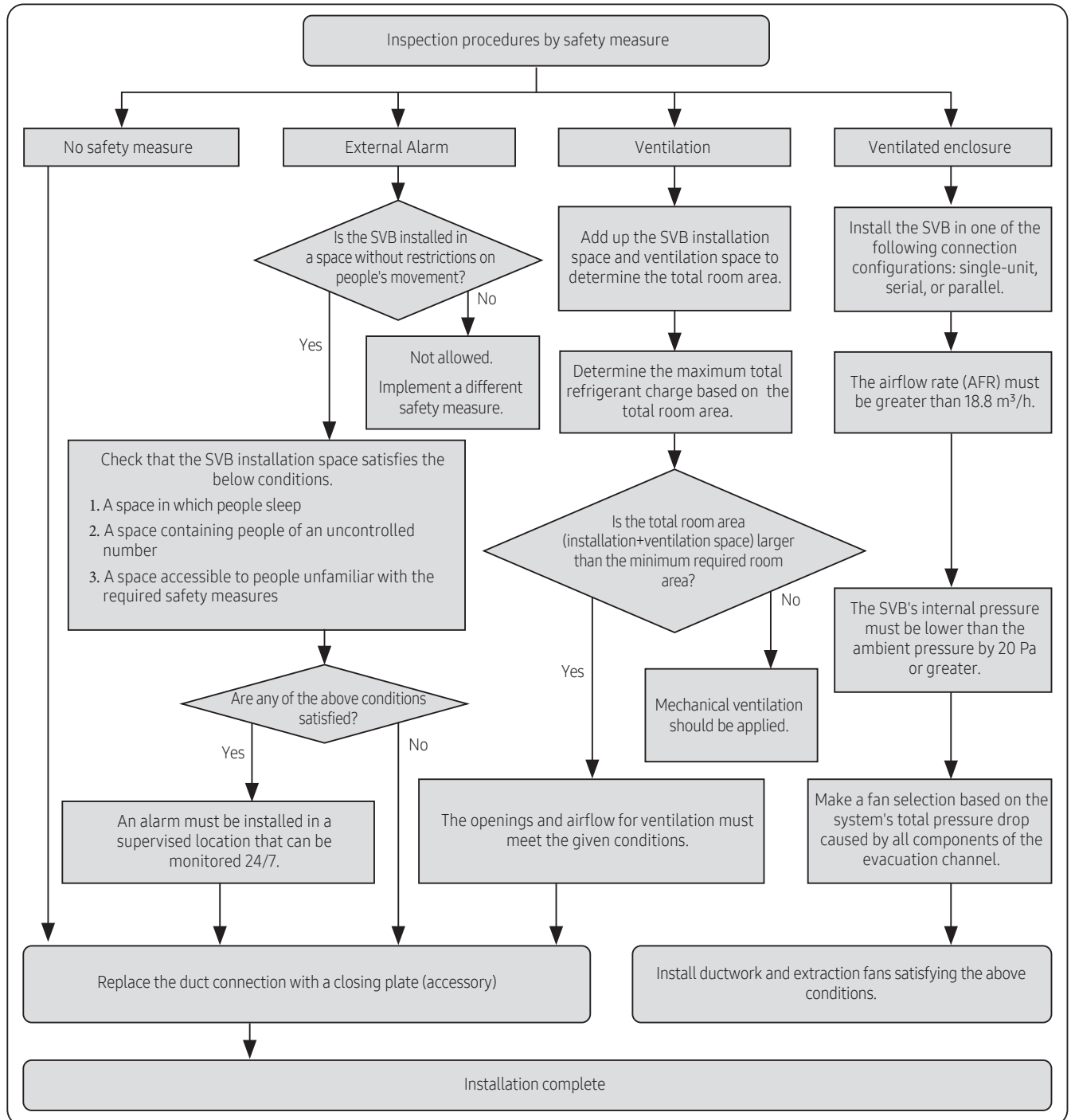

※ Installation

SVB (Shut off Valve Box)

Space requirements

- 1 Refrigerant noise can be generated during SVB operation. Do not install the unit in spaces that require silence, such as bedrooms, libraries, hospitals, offices etc.

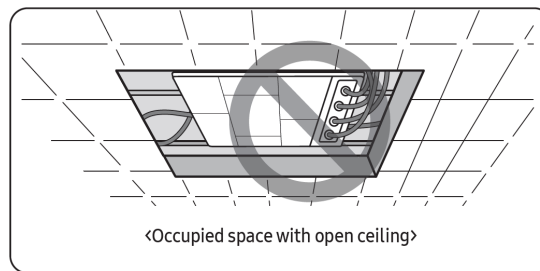

- 2 Do not install the SVB in the ceiling of living spaces.
Noise generated from the SVB may disrupt occupant comfort.

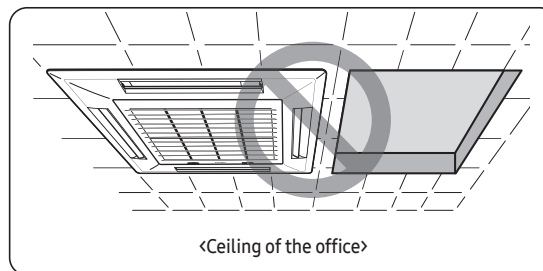

- 3 It is normally recommended to install SVB in a hallway but a bulkhead should be installed to minimize the noise from being transferred to living area. (Refer to the below figure)

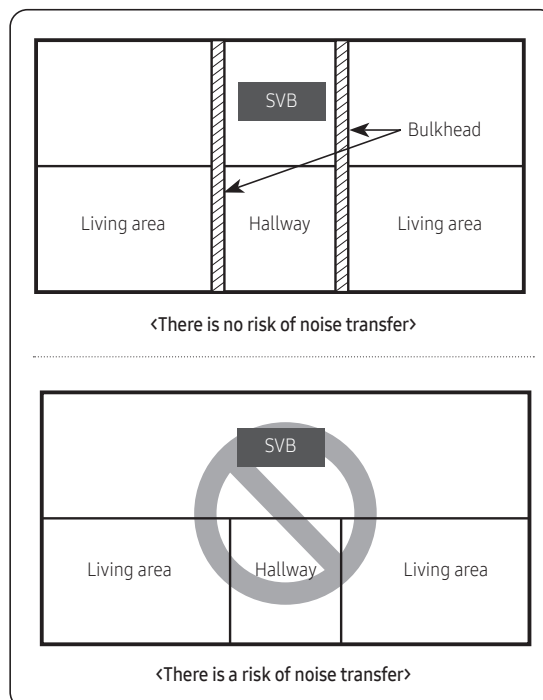

※ Installation

SVB (Shut off Valve Box)

※ Soundproof and soundproofing materials

- The place where SVB is installed and the interior walls should have a high soundproof ability. (Bricks, Concretes, Cement)
 - The ceiling where SVB is installed should be coated with quality textile that has a good soundproof function.
 - Minimize the size of the hole between the walls and the pipe connection. After the installation, block the gap to prevent noise from leaking.
- 4 Secure over 0.25 m (0.82') of space when SVB is being fixed to the concrete of the ceiling.
 - 5 SVB may generate noise so don't install it too close to the ceiling textile.
 - 6 Each pipe hanger should be placed at 1.5 m (4.92') interval to support its weight firmly. If the pipe or the hanger isn't fixed firmly, the unit may fall and cause a property damage or loss of life.
 - 7 When 'Low temperature cooling range expansion' option is set for constant cooling operation throughout the year, noise of the SVB may get louder during wintertime. Therefore, above installation requirements must be followed.
 - 8 Select a place where the structure can support the weight of the SVB and indoor units that also have strong vibration resistance without any slope. If the structure is not strong enough, SVB may fall down and cause injury.

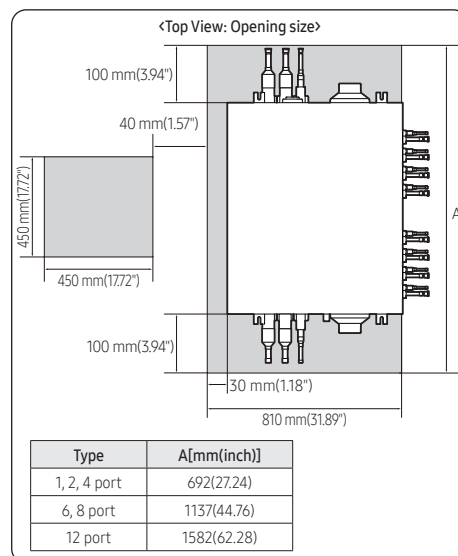
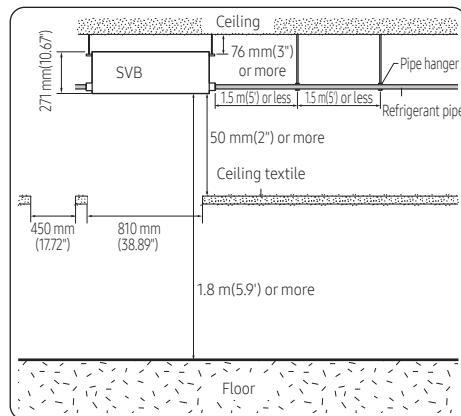

※ Installation

SVB (Shut off Valve Box)

- 9 Select an installation location with enough space for service and repair.
Leave enough space between adjacent walls and structures. Refer to the examples below.

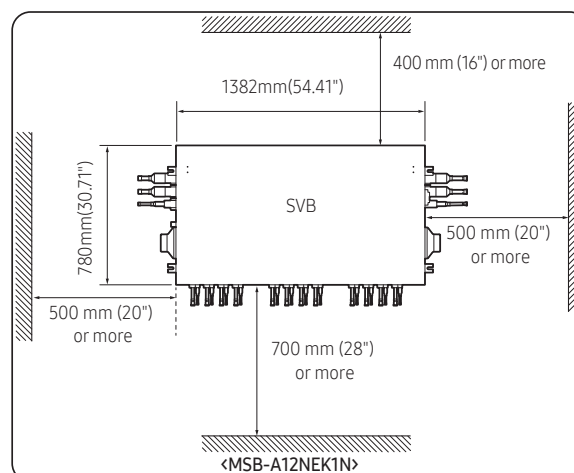
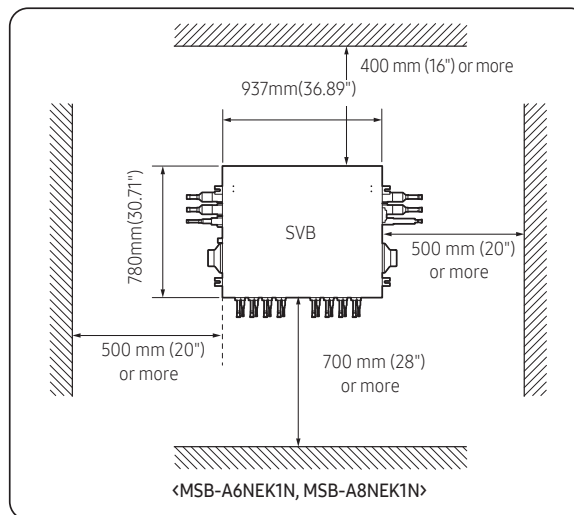
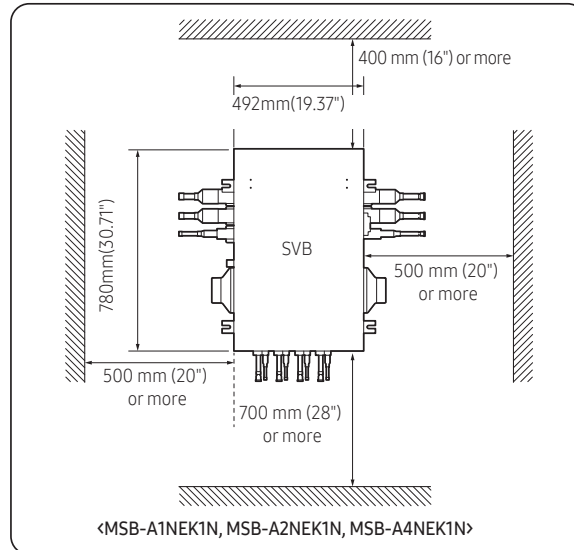

※ Installation

SVB (Shut off Valve Box)

1 SVB specification

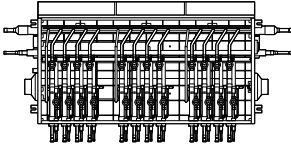
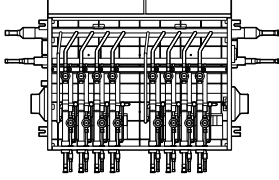
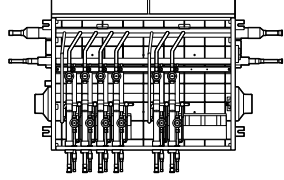
Model	MSB-A12NEK1N	MSB-A8NEK1N	MSB-A6NEK1N
Exterior of SVB			
Number of connectable indoor units at one port	Up to 8 units	Up to 8 units	Up to 8 units
Maximum number of indoor units (Total)	64	64	32
The maximum capacity of the connectable indoor units at one port	16 kW (54MBH)	16 kW (54MBH)	16 kW (54MBH)
The maximum capacity of the connectable indoor units at one port (with Y-JOINT)	32.0 kW (108 MBH)	32.0 kW (108 MBH)	32.0 kW (108 MBH)
The maximum capacity of the connectable indoor units	85.0 kW (290MBH)	85.0 kW (290MBH)	61.6 kW (216MBH)

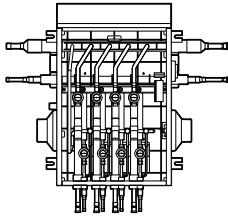
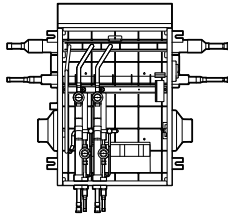
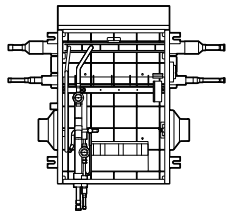
Model	MSB-A4NEK1N	MSB-A2NEK1N	MSB-A1NEK1N
Exterior of SVB			
Number of connectable indoor units at one port	Up to 8 units	Up to 8 units	Up to 8 units
Maximum number of indoor units (Total)	32	16	8
The maximum capacity of the connectable indoor units at one port	16 kW (54MBH)	16 kW (54MBH)	16 kW (54MBH)
The maximum capacity of the connectable indoor units at one port (with Y-JOINT)	32.0 kW (108 MBH)	32.0 kW (108 MBH)	-
The maximum capacity of the connectable indoor units	61.6 kW (216MBH)	32.0 kW (108MBH)	16 kW (54MBH)

⚠ CAUTION

- If the sum of the connected indoor unit capacity connected to the SVB is greater than 67.2kW (228 MBH), performance may vary depending on operating conditions.
- The incoming pipe diameters supplying refrigerant to the SVB are determined based on the sum of the connected indoor units. If these pipe diameters are different than the SVB pipe diameters, use the provided reducers to connect to the SVB. If the provided reducers are not the correct size, field supplied reducers must be used.

※ Installation

SVB (Shut off Valve Box)

2 Installing the indoor units

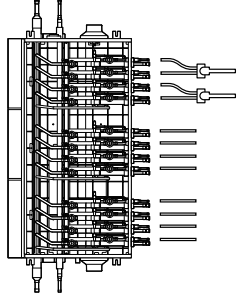
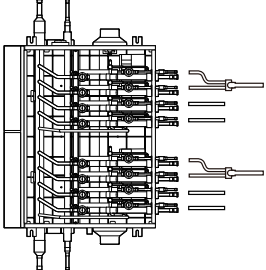
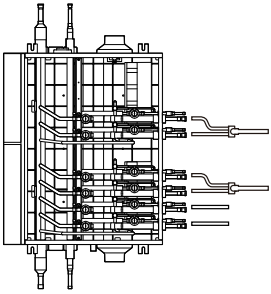
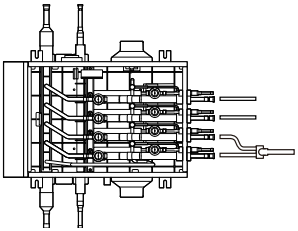
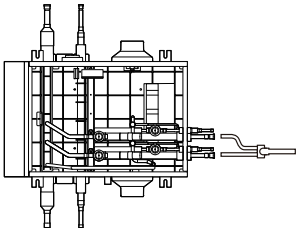
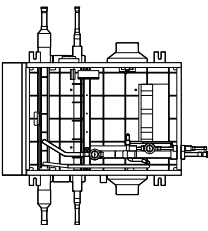
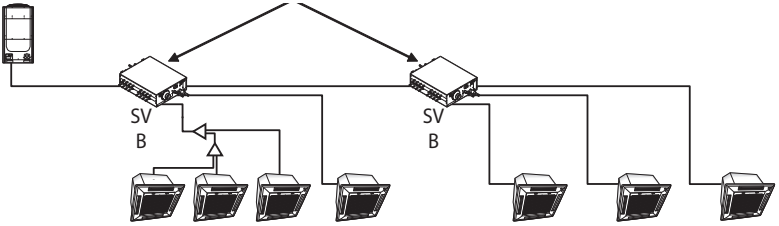
Model	MSB-A12NEK1N	MSB-A8NEK1N	MSB-A6NEK1N
Example installing (Each port connection)			
			
Example installing (SVB series connection)	 <p style="text-align: center;">SVB series connection</p>		
Installing indoor units	<p>Indoor units under 16.0 kW (54 kBtu/h): Y-connector is not required</p> <p>Indoor units 16.0 kW ~ 32.0 kW (54 ~ 108 kBtu/h): Y-connectors at the gas and liquid lines are required</p> <p>Only one indoor unit can be connected after connecting two SVB ports with a Y-joint.</p> <p>If continuous cooling operation is required when outside temperature is below -5 °C (23 °F), set outdoor option setting "Expand operational temperature range for cooling operation (HR only)", and use Y-connector on the liquid and gas pipes for indoor units 5.0 ~ 16 kW (18 ~ 54 kBtu/h).</p> <p>When SVBs are connected in series, the maximum capacity of all indoor units in SVB series connection is the larger value of SVB which are connected in series.</p> <p>Example: MSB-A12NEK1N + MSB-A6NEK1N → 85.0 kW (290MBH)</p>		

※ Installation

SVB (Shut off Valve Box)

3 Preparation before installation.

- a Place the pattern sheet on the ceiling at the spot where you want to install the indoor unit.

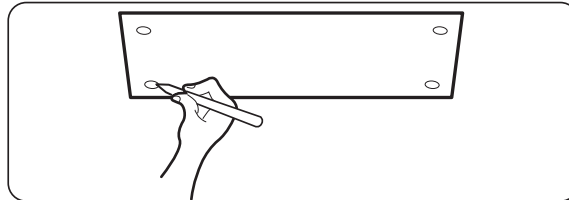

NOTE

- Since the diagram is made of paper, it may shrink or stretch slightly due to temperature or humidity. For this reason, before drilling the holes maintain the correct dimensions between the markings.
- b Insert bolt anchors, use existing ceiling supports or construct a suitable support as shown in figure.

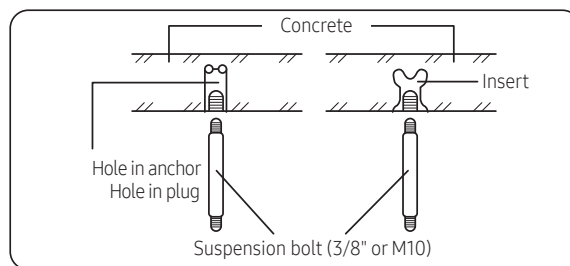

- c Install the suspension bolts depending on the ceiling type.

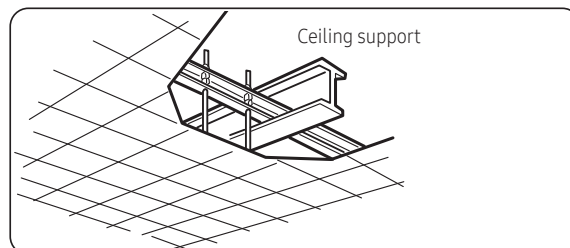

CAUTION

- Ensure that the ceiling is strong enough to support the weight of the unit. Before hanging the unit, test the strength of each attached suspension bolt.
- If the length of suspension bolt is more than 1.5 m (4.92'), it is required to prevent vibration.
- If this is not possible, create an opening on the false ceiling in order to be able to use it to perform the required operations on the indoor unit.

※ Installation

SVB (Shut off Valve Box)

4 Cautions about SVB installation.

- When fixing the unit at the upper place using suspension bolts, use a nut and washer to vertically fasten the unit.
- The SVB has four suspension points to secure the SVB. All four suspension points must be used.
- Take care to ensure that the unit is installed in the correct orientation. If the SVB is installed upside down, noise will be generated and the unit may be damaged.
- Level the unit at all 4 corners by turning nuts or washers. A deviation of maximum 1 degree is allowed in the direction away from the control box.

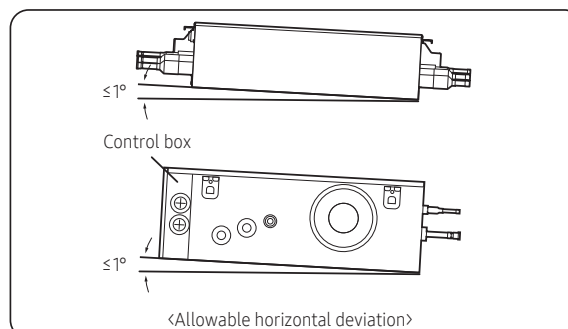
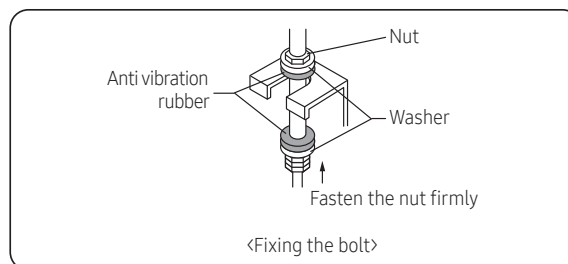
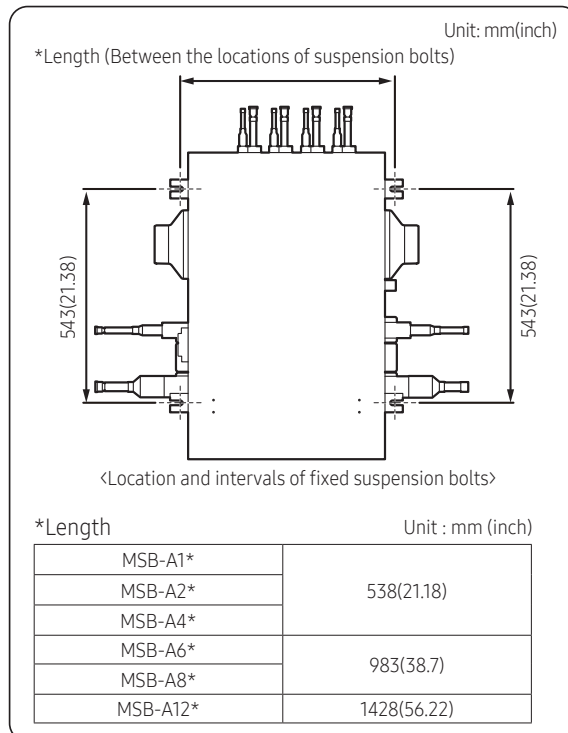

※ Installation

SVB (Shut off Valve Box)

5 How to connect the pipe line.

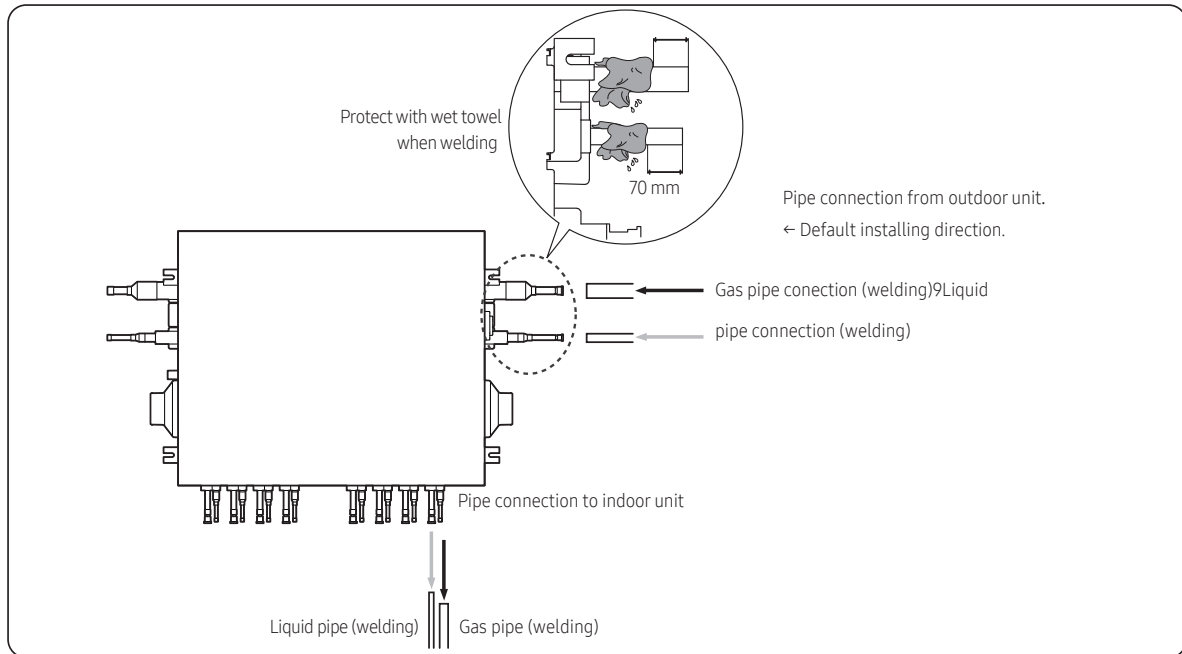

- ※ When installing SVB, use the pattern sheet for installation that is provided with the product.
- ※ When welding the pipes, protect the product with the flame-proof sheet.
- ※ When connecting the SVB with outdoor units, default direction is set in the SVB.
If installing opposite direction, weld the enclosed copper cap to each high pressure, low pressure and liquid pipes.
- ※ When there are remaining ports not connected to the indoor unit, pinch them with pliers and then weld them to completely seal them.

6 How to connect Y-connector

- In case of connecting one indoor with Y-Connector to SVB, Y-Connector must be connected in series.

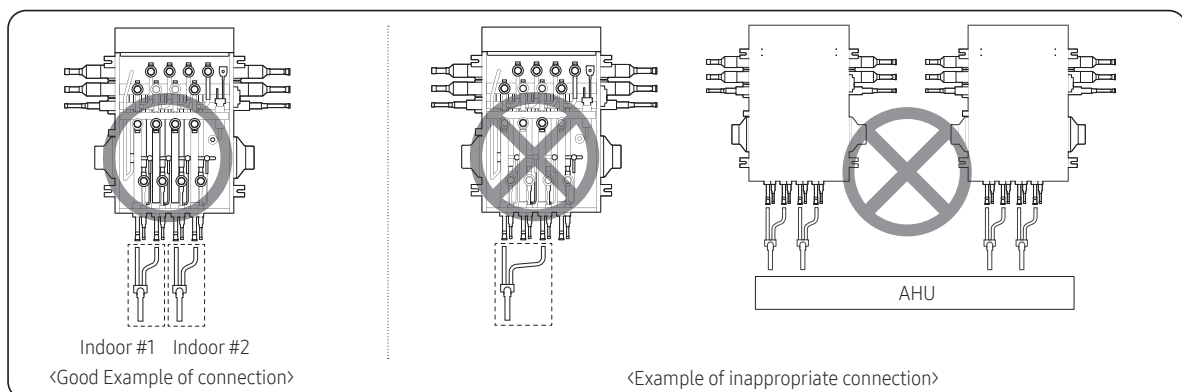

※ Installation

Wiring

Installing the circuit breaker and wires-

Power supply	MCCB	ELB	Power cable	Earth cable	Communication cable
Max : 242V Min : 198V	x [A]	x [A], 30mmA 0.1 sec	AWG 12 (2.5 mm ²)	AWG 12 (2.5 mm ²)	AWG 14 (0.75~1.5 mm ²)

※ $x [A] \geq 1.25 \times 1.1 \times \sum A_i$
 (x [A] : MCCB/ELB amperes, $\sum A_i$: Sum of the rated current amperes of indoors)

Installing the wire

- Supply the 220-240V/208-230V power to L1, L2 (L, N) of SVB separately.
- Connect the communication cable from the outdoor unit to F1, F2 of SVB.
- Power Line and communication line must be connected as shown in drawing.

Case 1

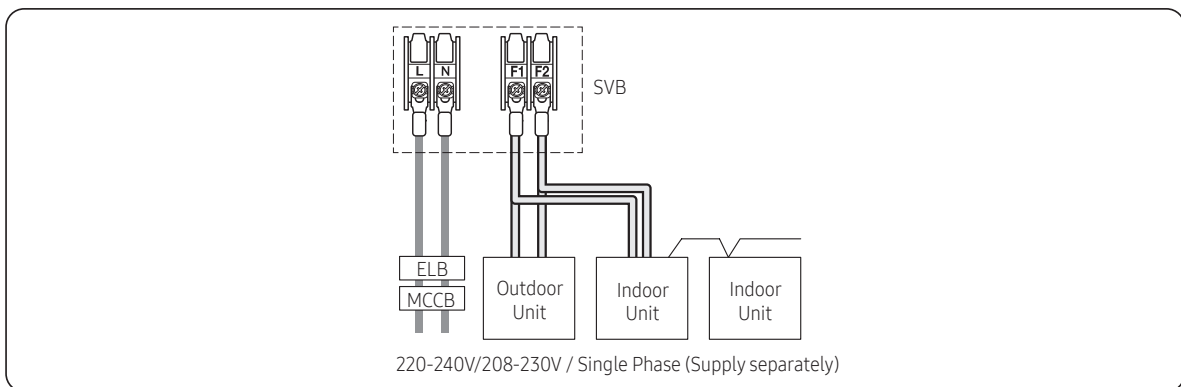

Case 2

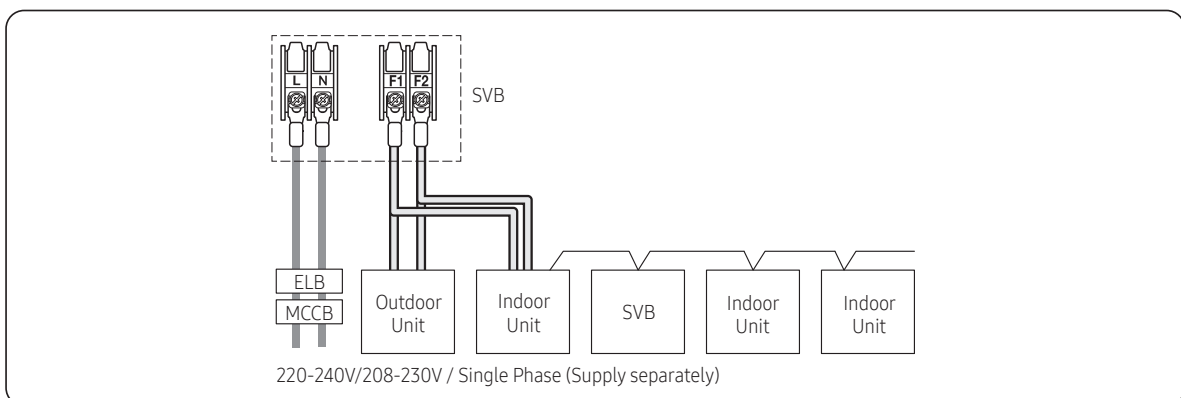

※ Installation

Case 3

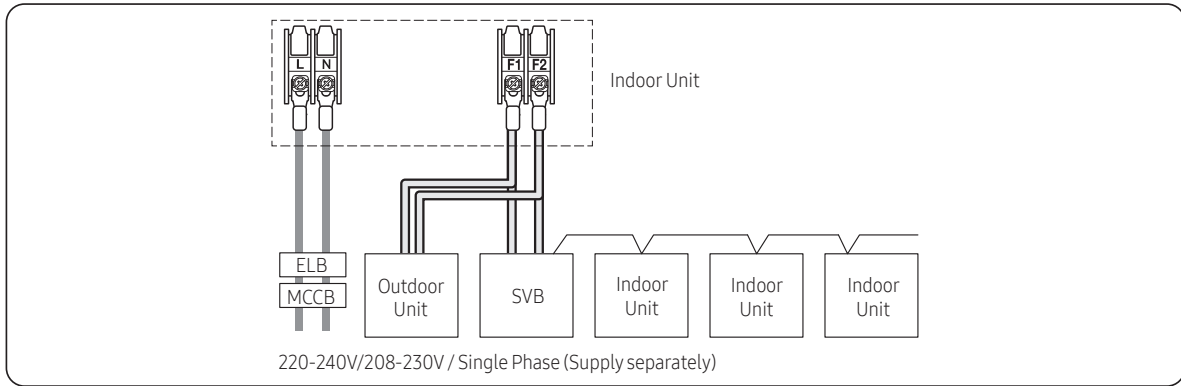

- Power line and communication line must be installed as shown in drawing
※ Hole size is Φ 43.7 mm (1.72 inches)

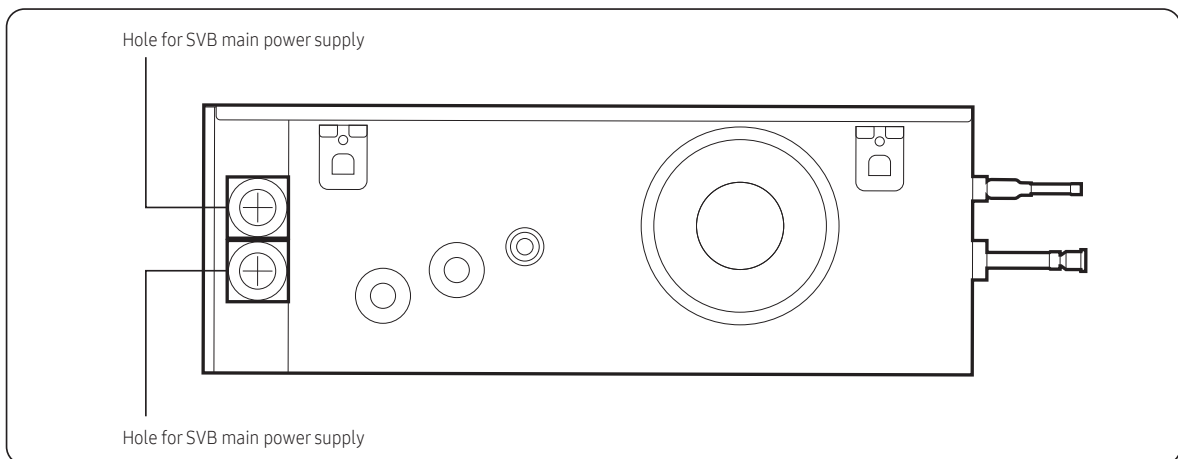

※ Installation

SVB (Shut off Valve Box)

- Choose the compressed socket based on the cross-section of the connecting wire.

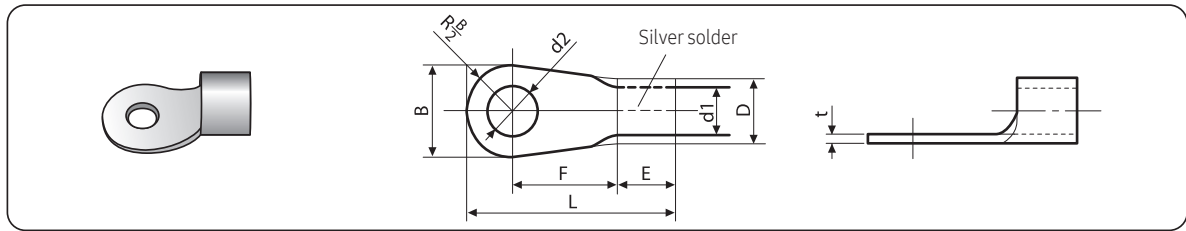

Nominal dimensions for cable [mm ² (inch ²)]		1.5 (0.002)		2.5 (0.003)		4 (0.006)
Nominal dimensions for screw [mm (inch)]		4 (0.157)	4 (0.157)	4 (0.157)	4 (0.157)	4 (0.157)
B	Standard dimension [mm (inch)]	6.6 (0.259)	8 (0.314)	6.6 (0.259)	8.5 (0.334)	9.5 (0.374)
	Allowance [mm (inch)]	±0.2 (0.007)		±0.2 (0.007)		±0.2 (0.007)
D	Standard dimension [mm (inch)]	3.4 (0.134)		4.2 (0.165)		5.6 (0.220)
	Allowance [mm (inch)]	+0.3 (0.011)		+0.3 (0.011)		+0.3 (0.011)
		-0.2 (-0.007)		-0.2 (-0.007)		-0.2 (-0.007)
d1	Standard dimension [mm (inch)]	1.7 (0.066)		2.3 (0.090)		3.4 (0.133)
	Allowance [mm (inch)]	+0.2 (±0.007)		+0.2 (±0.007)		+0.2 (±0.007)
		0		0		0
E	Min. [mm (inch)]	4.1 (0.161)		6 (0.236)		6 (0.236)
F	Min. [mm (inch)]	6 (0.236)		6 (0.236)		5 (0.196)
L	Max. [mm (inch)]	16 (0.629)		17.5 (0.688)		20 (0.787)
d2	Standard dimension [mm (inch)]	4.3 (0.169)		4.3 (0.169)		4.3 (0.169)
	Allowance [mm (inch)]	+0.2 (±0.007)		+0.2 (±0.007)		+0.2 (±0.007)
		0		0		0
t	Min. [mm (inch)]	0.7 (0.027)		0.8 (0.031)		0.9 (0.035)

2025.12
Ver. 2.0

Samsung Electronics Co., LTD.

Head Office (Suwon Korea) 129, Samsung-Ro, Yeongtong-Gu, Suwon City, Gyeonggi-Do, Korea 16677

Website : www.samsung.com, <https://hvachub.samsung.com> Email : hvachub@samsung.com

Images and data in this book may subject to change without prior notice.